

FORCEmeter™

ForceMeter™ Strain Gage Installation & Operation Manual

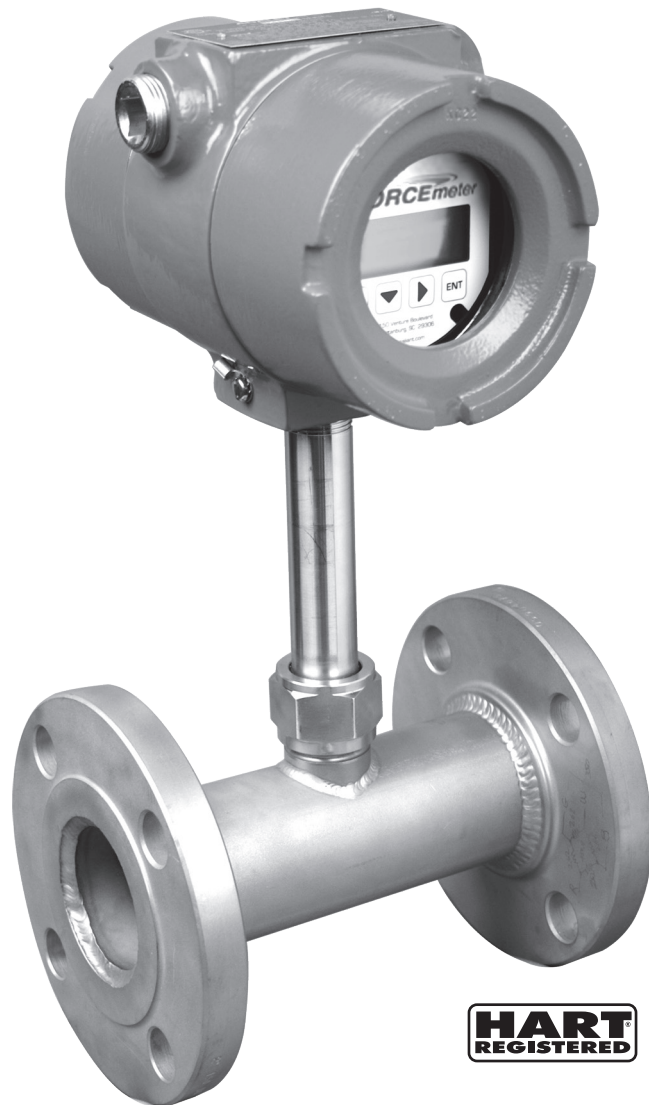

HART
REGISTERED



ForceMeter™ Strain Gage Installation & Operation Manual

CONTENTS

I. HANDLING & STORAGE	1
Inspection and Handling	
Disposal and Recycling	
Storage	
II. GENERAL SAFETY	2
Authorized Personnel	
Use	
Misuse	
III. PRODUCT DESCRIPTION	3
Function	
Figure 1: Four Arm Bridge Circuit	
Figure 2: Equivalent Forces	
Applications	
Technical Specifications	
Approvals	
IV. MECHANICAL INSTALLATION	7
Mounting	
Inline	
Figure 3: Wafer, 150# RF & MNPT	
Insertion Probe Mounting	
Figure 4: Flange Bolt Hole Configuration	
Figure 5: Fixed Insertion	
Retractable Probe Mounting	
Figure 6: Retractable Probe Dimensional Drawing	
Figure 7: Parts List	
Remote Enclosure Mounting	
V. ELECTRICAL INSTALLATION	12
General Safety	
Disconnect Requirements for Permanently Installed Equipment	
Protective Earth Ground	
Electrical - 2 Wire	
Integral Transmitter - 2 Wire	
Figure 8: Integral Transmitter Wiring - 2 Wire	
Remote Transmitter - 2 Wire	
Figure 9: Remote Transmitter Wiring - 2 Wire	
HART Communication - 2 Wire	
Figure 10: HART Wiring Integral Transmitter - 2 Wire	

- Figure 11. HART Wiring Remote Transmitter - 2 Wire
Electrical - 3 Wire
Integral Transmitter - 3 Wire
- Figure 12: Integral Transmitter Wiring - 3 Wire
Remote Transmitter - 3 Wire
- Figure 13: Remote Transmitter Wiring - 3 Wire
HART Communication - 3 Wire
- Figure 14: HART Wiring Integral Transmitter - 3 Wire
- Figure 15: HART Wiring Remote Transmitter - 3 Wire

VI. SET-UP	18
Transmitter Menu Options	
Program Mode Information	
Calibration	
VII. MAINTENANCE	26
VIII. TROUBLESHOOTING	26
IX. DIMENSIONAL DRAWINGS	28
Figure 16: Retractable Insertion	
Figure 17: Fixed Insertion	
Figure 18: Standard Mounting Option	
Figure 19: Remote Enclosure	
Figure 20: Remote Enclosure Conduit Entry Locations	
X. WARRANTY	30
XI. APPENDIX	30

SAFETY SYMBOLS



WARNING:

IDENTIFIES CONDITIONS OR PROCEDURES, WHICH IF NOT FOLLOWED, COULD RESULT IN SERIOUS INJURY. RISK OF ELECTRICAL SHOCK.



CAUTION:

IDENTIFIES CONDITIONS OR PROCEDURES, WHICH IF NOT FOLLOWED, COULD RESULT IN SERIOUS DAMAGE OR FAILURE OF THE EQUIPMENT.

ForceMeter™ Strain Gage Installation & Operation Manual

I. HANDLING AND STORAGE

SAVE THESE INSTRUCTIONS

INSPECTION AND HANDLING

Do not dispose of the carton or packing materials.

Each package should be inspected upon receipt for damage that may have occurred due to mishandling during shipping. If the unit is received damaged, notify the carrier or the factory for instructions. Failure to do so may void your warranty. If you have any problems or questions, consult Niagara Meters Customer Support at 800-778-9251.

DISPOSAL AND RECYCLING

This product can be recycled by specialized companies and must not be disposed of in a municipal collection site. If you do not have the means to dispose of properly, please contact for return and disposal instructions or options.

STORAGE

If the device is not scheduled for immediate installation following delivery, the following steps should be observed:

1. Following inspection, repackage the unit into its original packaging.
2. Select a clean dry site, free of vibration, shock and impact hazards.
3. If storage will be extended longer than 30 days, the unit must be stored at temperatures between 32° and 158° F (0° to 70° C) in non-condensing atmosphere with humidity less than 85%.



CAUTION: DO NOT STORE A NON-POWERED UNIT OUTDOORS FOR A PROLONGED PERIOD.

II. GENERAL SAFETY

AUTHORIZED PERSONNEL

All instructions described in the document must be performed by authorized and qualified service personnel only. Before installing the unit, please read these instructions and familiarize yourself with the requirements and functions of the device. The required personal protective equipment must always be worn when servicing this device.

USE

The device is solely intended for use as described in this manual. Reliable operation is ensured only if the instrument is used according to the specifications described in this document. For safety and warranty reasons, use of accessory equipment not recommended by the manufacturer or modification of this device is explicitly forbidden. All servicing of this equipment must be performed by qualified service personnel only. This device should be mounted in locations where it will not be subject to tampering by unauthorized personnel.

MISUSE

Improper use or installation of this device may cause the following:

- Personal injury or harm
- Application specific hazards such as vessel overflow
- Damage to the device or system

If any questions or problems arise during installation of this equipment, please contact Customer Support at 800-778-9251.

III. PRODUCT DESCRIPTION

FUNCTION

The ForceMeter is available in a wide variety of sizes, materials, connections and flow ranges. It is a universal flow meter due to its effectiveness with liquids, gas, and steam, both superheated and saturated. Typical accuracies are of 1% of rate over a 15:1 turndown.

The ForceMeter provides flow measurement by sensing the fluid force acting on the target suspended in the flow stream. The following equation describes the operation of the strain gage target flow meter:

$$\text{Force} = C_d A \rho \frac{V^2}{2g}$$

C_d = Overall drag coefficient obtained from empirical data

A = Target area

ρ = Fluid density

V = Fluid velocity at the point of measurement

g = Gravitational force of the earth

In a given flow application, the drag coefficient, target area, and gravitational force would be constant. The flow meter is actually measuring the following:

$$\text{Fluid density} \times \text{fluid velocity}^2$$

Flow is equal to the square root of the force. The transmitter amplifies the output signal, extracts the square root, and produces a linear analog (4-20 mA) output with HART communication.

A typical strain gage target flow meter consists of the sensing element, mounting flange or housing, and a terminal strip or transmitter enclosed in a junction box.

The sensing element consists of a wiring connector, target rod, calibrated target, mounting base, protective case, and the sensing tube where the actual strain gages are attached.

Four strain gages (variable resistors) are attached to the sensing tube, two on the leading side of flow, and two on the trailing side of flow. The strain gages are inter-connected, forming a four active arm strain gage bridge circuit. At zero flow (no force on the target), the bridge circuit is balanced, producing zero output. Flow produces a strain on the sensing tube, compressing the leading side strain gages and tensing the trailing side strain gages, causing their resistance to decrease and increase respectively. The change in resistance of the strain gages offsets the bridge circuit, producing an output.

Figure 1. Four Arm Bridge Circuit

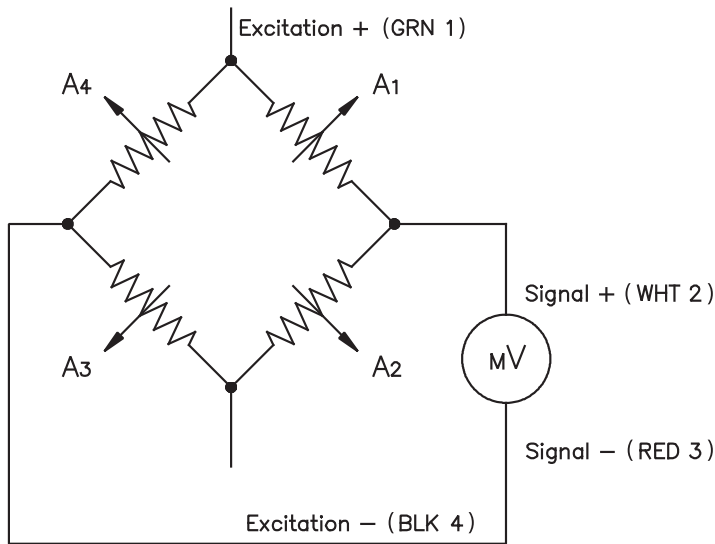

The calibration and range of the flow meter is determined by the target size. Given the flow parameters for an application and knowing the desired amount of stress to be applied to the sensing tube at full-scale flow, the approximate target size is determined. The flow meter is then tested in a flow test stand and the final target is obtained.

All fluid flow application can be mathematically converted to a water flow equivalent. This water flow equivalent represents the same force as the actual fluid application allowing water to be used as the primary calibration medium. The following applications all exert the same force on the target, producing the same bridge output:

Figure 2. Equivalent Forces

FLUID	SIZE	FLOW RATE	PSIG	DEGREE (F)
Saturated Steam	3"	3460 PPH	120	+350°
Air	3"	1080 SCFM	100	+70°
Water	3"	100 GPM	75	+45°
Liquid Nitrogen	3"	750 PPM	20	-300°

APPLICATIONS

ForceMeter are used to measure liquids, gas, or steam having sufficient momentum to exert enough force on the target for the sensing system to operate. This can include mild slurries. Special units with air purges have been used where particulates greater than 0.026 inches are in the flow stream.

STEAM

The strain gage target flow meter has all the features desired in a saturated or super-heated steam flow meter. It has an all-welded design, which eliminates potential leak paths created by seals, gaskets, or o-rings. It has a low-pressure drop, no moving parts (bearings, springs), and is not damaged by slugs of condensate. The retractable flow version allows the flow meter to be inserted into service without shutting off the stream of flow. Seasonal flow ranges, such as large flow rates in the winter and small flow rates in the summer, can be easily obtained by changing targets.

BI-DIRECTIONAL

The strain gage bridge circuit technology, which measures the force produced by flow, will measure both forward and reverse force. The polarity of the output signal indicates the direction of the flow, making the target meter a true bi-directional flow meter. A special target is used to ensure accuracy in both directions.

TECHNICAL SPECIFICATIONS

The sensing element, the heart of the flow meter, can be installed in any line size and in almost any mounting configuration. Inline flow meters, supplied with mounting housing such as wafer, flanged, MNPT, and flare tube, are available for one half to six inch line sizes. Fixed insertion type flow meters are available for line sizes of four to sixty inches. Retractable insertion type flow meters are available for line sizes of four to thirty six inches.

The type of mounting configuration limits the pressure rating of the flow meter. In flow meters that have a flange, the flange determines the maximum operating pressure. The strain gage sensing element is available in three pressure ratings: 1000, 5000 and 10,000 PSIG. The meter is available in three temperature ranges, from -65° to $+425^{\circ}$ F, -65° to $+500^{\circ}$ F, and -320° to $+250^{\circ}$ F.

FUNCTIONAL	
Fluid Types	Liquids (Reynolds numbers greater than 2000), gases and steam
Bridge Resistance	5000 ohms \pm 30 ohms
Operating Pressure	Sensing Element: 1000, 5000, or 10,000 PSI Mounting Type / Connections: according to the appropriate ANSI specifications
Operating Temperature	-65° to 425° F (-54° to 218° C) standard; -65° to 500° F (-54° to 260° C) extended temp; -320° to 250° F (-195° to 121° C) cryogenic
Transmitter Temperature	-4° to 158° F (-20° to 70° C)
PERFORMANCE	
Accuracy	\pm 1.0% of rate
Repeatability	\pm 0.15% of rate
Turn Down	15:1 for 2 wire version; 20:1 for 3 wire version
Response Time	0.3 seconds
Damping	User adjustable settings 0 to 99 samples
Flow Direction	Unidirectional or bidirectional
Communications	HART® communication signal (superimposed on a 4-20 mA DC signal)
PHYSICAL	
Housing / Flanges	316L stainless steel (standard), others available
Rating	NEMA 4X
Mounting Positions	Horizontal, vertical or on an angle
Typical Straight Pipe Requirements	10 x the pipe diameter of straight uninterrupted pipe upstream 5 x the pipe diameter of straight uninterrupted pipe downstream
Process Connections	MNPT (0.5" to 3.0") ANSI Raised Face Flange (Class 150# standard, 0.5" to 6.0") Wafer (0.5" to 6.0") AN 37 Degree Flare Tube (0.5" to 2.0") Fixed Insertion Probes, 2" or 4" ANSI Raised Face Flange (Class 150# standard) Retractable Insertion Probes, 2" or 4" ANSI Raised Face Flange (Class 150# standard)
Transmitter Housing	Integral: Polyester powder coated aluminum, dual cavity Remote: Compression-molded fiberglass Remote Hazardous: Polyester powder coated aluminum, dual cavity
Power	18 to 36 VDC
Line Sizes	Inline 0.5" to 6.0", Insertion 4.0" to 60"
Electrical Connections	0.75" NPT
Remote Enclosure Rating	4X
Remote Enclosure Dimensions (with tabs)	7 x 8.5 x 4.5 inches (17.8 x 21.5 x 11.4 cm)
ACCESSORIES	
	Rate/Total Indicator, Batch Controller, Mass Flow Computer (gases or steam)
OPTIONS	
	350 ohms \pm 5 ohms for 3 wire only

APPROVALS

CE Electromagnetic Compatibility Directive (EMC)

FM: XP Class I, Div 1, Groups B, C, D

DIP Class II & III, Div 1, Groups E, F, G

IV. MECHANICAL INSTALLATION



CAUTIONS: CARE SHOULD BE EXERCISED IN REMOVING THE FORCEMETER FROM ITS PACKING CRATE OR CARTON AND IN INSTALLING IT IN THE LINE. DO NOT DAMAGE SEALING SURFACES SUCH AS FLANGE GASKET SURFACES AND PIPE THREADS. AVOID LIFTING THE FORCEMETER BY THE TARGET (DISC) OR TARGET LEVER ROD. AVOID DAMAGE TO THE TARGET.

MOUNTING

The ForceMeter should be installed on the upstream side of any flow controls or shut off valves to ensure complete immersion of the target in the fluid at all rates of flow.

The meter must typically be preceded by at least ten diameters of straight, uninterrupted flow line and followed by a minimum of five diameters. Do not precede the instrument with flexible corrugated tubing. Some applications require a minimum of twenty diameters and followed by a minimum of ten diameters of straight uninterrupted flow line. "Pipe diameter" is the straight length of pipe divided by the nominal pipe size.

There are up and down stream piping requirements due to velocity profile and Reynolds Number. The requirements vary depending on size, piping, and distances from elbows, pumps, or control valves.

INLINE

Figure 3. Wafer, 150# RF & MNPT

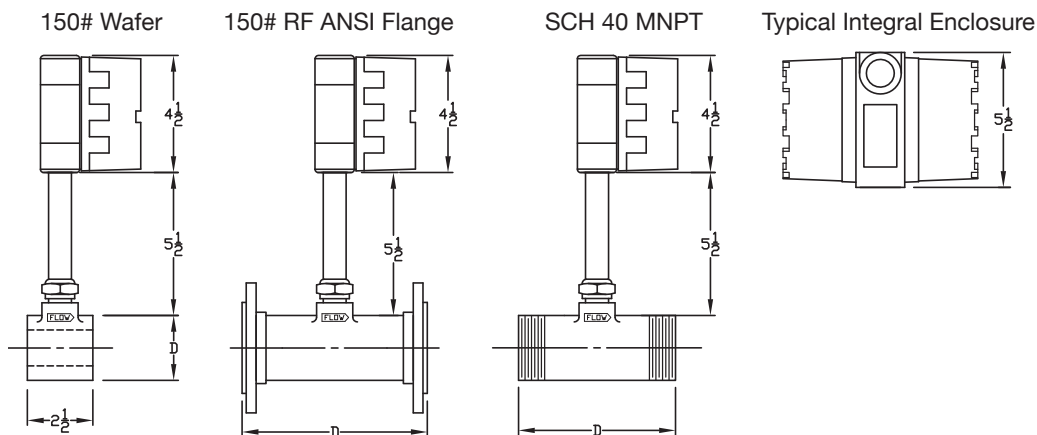

"D" Dimension

Size	Wafer	150# RF		MNPT	
		Dim.	Wt (lbs)	Dim.	Wt (lbs)
1/2"	1 3/4"	5"	8	4"	6
3/4"	2 1/8"	5"	9	4"	6
1"	2 1/2"	5"	9	5"	6
1 1/4"	2 7/8"	6"	11	6"	7
1 1/2"	3 1/4"	6"	12	6"	7
2"	4"	8"	18	8"	7
3"	5 1/4"	9"	28	9"	9
4"	6 3/4"	10 1/2"	40	-	-
6"	8 5/8"	12 1/2"	60	-	-

Dimensions

Size	A	B	C	D	Wt (lbs)
1/2"	3.600"	1 3/8"	1 1/16"	7 5/8"	2.250
3/4"	3.600"	1 3/8"	1 1/16"	7 5/8"	2.250
1"	3.666"	1 3/8"	1 1/16"	7 5/8"	2.250
1 1/4"	3.666"	1 11/16"	7/8"	7 5/8"	2.500
1 1/2"	3.760"	1 15/16"	1	8 1/8"	3.000
2"	4.260"	2 9/16"	1 5/16"	8 5/8"	4.500

INSERTION PROBE MOUNTING

A flanged stub must be fabricated on the pipeline. Either a 2" or 4" ANSI flange is required. Refer to the meter model number on the data sheet for the flange size and rating. Figure 4. Flange Bolt Hole Configuration demonstrates the dimensions of the stub and orientation of the flange bolt holes. The inside configuration of this stub must be as shown on the drawing to permit the target to be inserted and withdrawn without interference. To guarantee target alignment, be sure the flange bolt holes straddle the pipe centerline.

Figure 4. Flange Bolt Hole Configuration

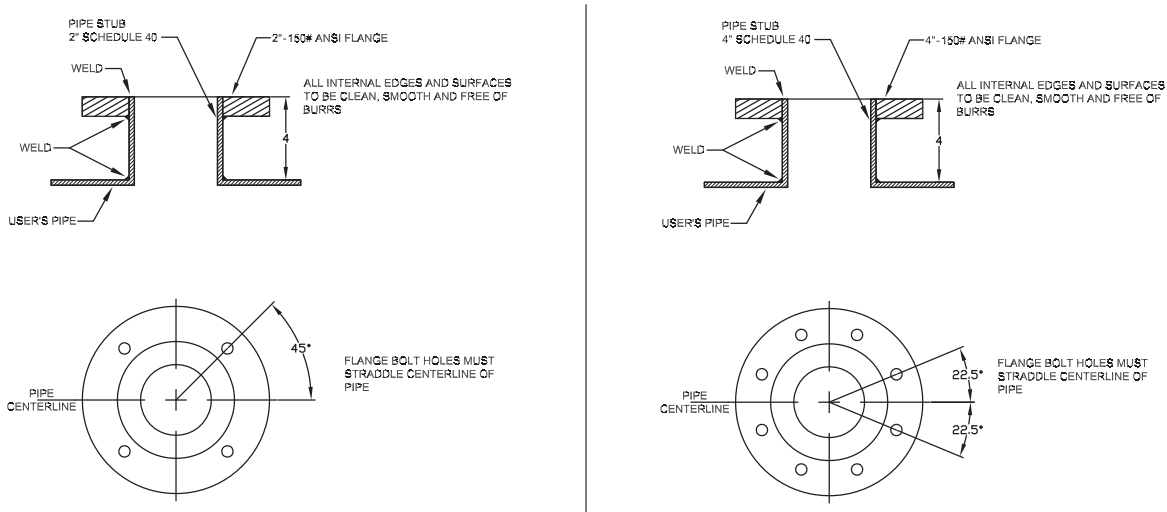
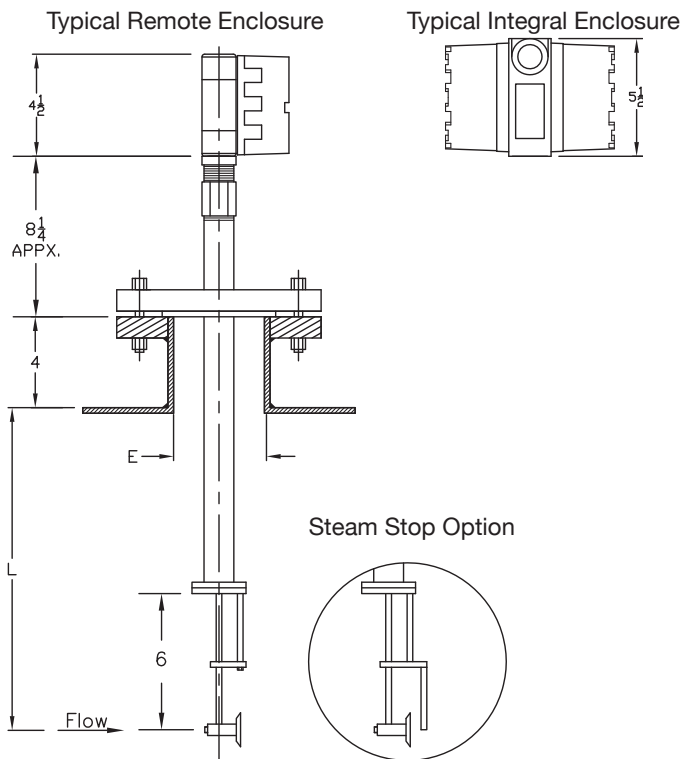

Figure 5. Fixed insertion



RETRACTABLE PROBE MOUNTING



WARNING: DO NOT TURN THE HAND WHEEL, ANY KNOBS, OR THE LOCK BOLTS UNTIL INSTRUCTED TO DO SO. READ ANY TAGS AND OBSERVE THE PRECAUTIONS PRINTED ON THEM.

The ForceMeter must be preceded by at least twenty diameters of straight uninterrupted flow line and followed by a minimum of ten diameters. Ideally, the total length of straight pipe should be broken only where the flowmeter is inserted. Exceptions are full bore ball valves, small dead-end (no flow) pressure taps and thermowells. Steam traps should be located just ahead of and just beyond the straight run. If a bidirectional flow measuring unit has been ordered, the ForceMeter should have 20 diameters of straight pipe on each side of the meter unless the reverse flow accuracy is less important.

The use of steam traps, while at the option of the user, is strongly recommended in saturated steam systems. The use of the traps minimizes the accumulation of condensate in the bottom of the pipe. This accumulation changes the effective cross-sectional area of the pipe, introducing an error in the indicated flow rate. This condition affects all head-class flowmeters.

Figure 6. Retractable Probe Dimensional Drawing

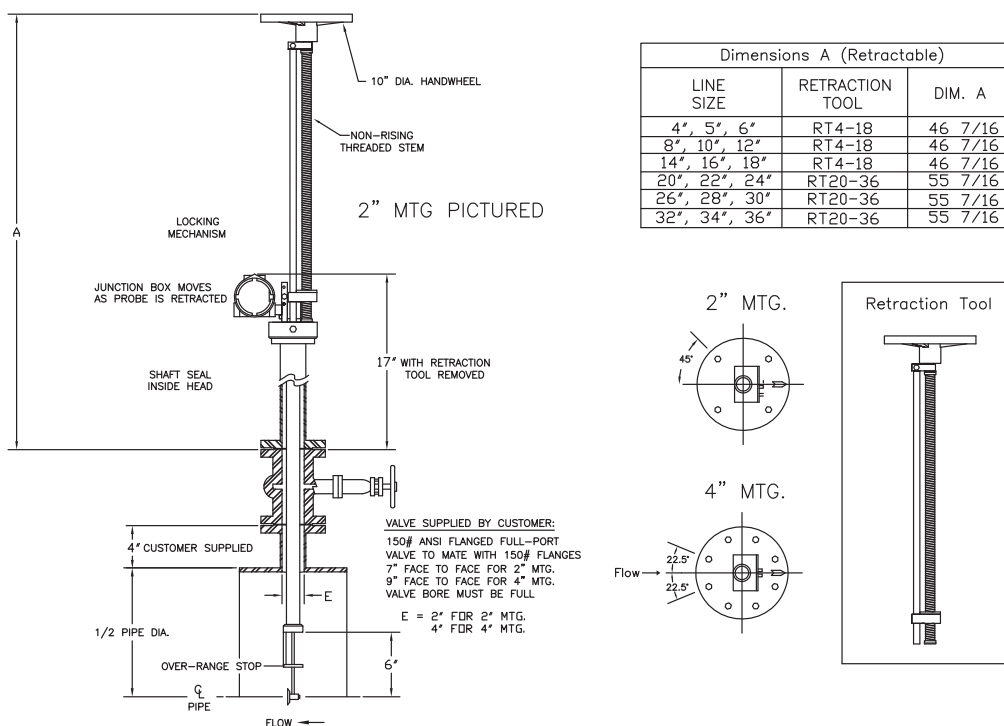

A gate valve or full-bore ball valve will be mounted to the stub flange, and the ForceMeter will be mounted to the valve. The retraction mechanism on the ForceMeter permits the sensing portion of the ForceMeter (the target) to be inserted or retracted while there is flow in the line. After retraction, the valve can be closed permitting removal of the ForceMeter without shutting down the pipeline.

For existing installations, it is possible to make a hot tap into a pipeline without shutting down the flow. After the cutting tool has been removed from the stub and valve, the ForceMeter can be installed.

The ForceMeter may be mounted in any position. The preferred position is with the pipe horizontal and the ForceMeter vertical.

NOTE: For a horizontal pipe, if possible try to avoid the 4 to 8 o'clock position to prevent sediment particles that might restrict force measurement. This arrangement makes it easier for the installer to position the ForceMeter and align the gaskets. It is advisable for the customer to inform the manufacturer of the chosen mounting position when placing the order. Integral pressure and temperature sensors, if included, do not affect the piping requirements.

The target and its support will have to move into and out of the line freely. All of the parts through which the target passes should be in alignment with the stub flange. This includes the valve, the gaskets on both sides of the valve and flowmeter. This is particularly important if the ForceMeter is mounted horizontally.

Use four wooden dowels in the bolt holes to align the parts. The dowel diameter should be $\frac{3}{32}$ " greater than that of the bolts. Replace the dowels with the bolts, one at a time.

NOTE: For single unit orders with a Retraction Tool the tool is assembled on the meter. Refer to the ForceMeter outline drawing for location of the various flowmeter parts. See Figure 7. Parts list. The lock bolt is to be inserted once the ForceMeter is placed into the line, it can be found attached to the main meter housing.

Multiple units are shipped with the Retraction Tool separated from the ForceMeter. Bolts and lock washers (4 each) for assembling the tool to the meter can be found attached with a tie wrap to the hand wheel. The lock bolt, inserted once the ForceMeter is placed in the line, can be found attached to the ForceMeter main housing.

Before attaching the meter to the isolation valve, assemble the tool to the main housing. Raise the guide plate to the fully retracted position near the hand wheel. Locate the necessary hardware for mounting the retraction tool.

Insert the tie rods and threaded rod assembly into the main housing. Thread two larger screws (item 13, Figure 7) screws and split lock washers (item 16, Figure 7) through the main housing bolt holes into the tie rods and tighten securely. Using the hand wheel, bring the guide plate into the guide block. Using the two $\frac{1}{4}$ (20 x 1) screws (item 12, Figure 7) and $\frac{1}{2}$ inch split lock washers (item 15, Figure 7), thread these through the guide plate into the guide block and tighten securely.

BE SURE THE TARGET IS FULLY RETRACTED INTO THE MAIN HOUSING.

After the isolation valve has been properly assembled to the flange stub, attach the ForceMeter and a gasket to the isolation valve using good quality stainless steel bolts. The flow arrow on the flange must be pointing in the direction of flow. On bidirectional units the arrow indicates forward flow. Be sure to use a gasket between the ForceMeter and the isolation valve.

When the bolts have been properly tightened, open the valve. Do not turn the hand wheel until the valve is completely open. Turn the hand wheel until the target is inserted to the correct depth as indicated by the holes in the guide block and locking bar. Using the lock bolt $\frac{1}{4}$ (20 x 1.5) (item 14, Figure 7) that was taken from the main housing when beginning the installation of the tool, put the lock bolt in place and tighten.

It is recommended that, after the flowmeter is inserted, a chain be threaded through the valve and flowmeter hand wheels. The chain should be locked and a tag applied stating, "Retract flowmeter before closing valve."



CAUTION: BEFORE CLOSING THE VALVE AFTER INSTALLATION, IF RETRACTING THE METER BE SURE THE TARGET IS WELL CLEAR OF THE ISOLATION VALVE.

In some applications, the ForceMeter will be moved from one line to another. The ForceMeter limits this to 3 line sizes using the standard 4" mounting stub. The tool fits line sizes 4 to 18 inches or 20 to 36 inch line sizes in groups of 3. See Retractable Pipe Mounting for the sizes offered. Put the guide block in the correct position for the size selected, put the lock bolt in place and tighten.

REMOTE ENCLOSURE MOUNTING

1. Determine and clean location of remote enclosure; space should be at least 7.5 inches wide by 9 inches high (19.05 x 22.86 cm). See Dimensional Drawings section for detailed diagrams.
2. Screw tabs into the back of the enclosure, using screws provided – turning them to the desired angle.
3. Mark hole location on mounting location.
4. Depending on material of mounting location, pre-drill holes.
5. Hold enclosure and screw into mounting location, using screws provided by user.

Figure 7. Parts List

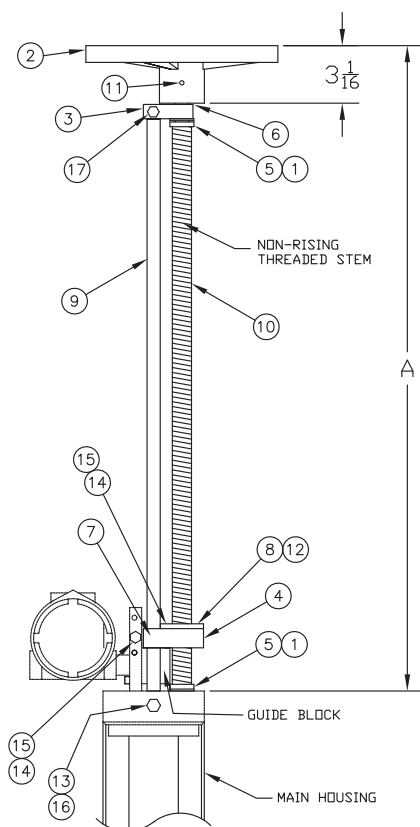

TOOL	TOOL	LINE SIZE	RETRACTION TOOL	DIM. A (in inches)		
RT20-36	RT4-18	4", 5", 6"	RT4-18	34 7/16		
		8", 10", 12"	RT4-18	34 7/16		
		14", 16", 18"	RT4-18	34 7/16		
		20", 22", 24"	RT20-36	43 7/16		
		26", 28", 30"	RT20-36	43 7/16		
		32", 34", 36"	RT20-36	43 7/16		
		Item List				
		2	2	17	SCR HEX HD 1/4-20X1 18-8	
		2	2	16	LWSHR SPLIT SST 3/8 5000	
		4	4	15	LWSHR SPLIT SST 1/4X.062	
4	4	14	SCR HEX HD 1/4-20X1.5			
2	2	13	SCR HEXHD 18-BSS 3/8-16X1			
4	4	12	SCR SDC HD18-BSS 1/4-20X1			
1	1	11	PIN ROLL SST .250 X 1.5			
1	1	10	STEM THRD 304S SIZE 36			
	1	10	THRD STEM SIZE 18			
2		9	TIE ROD SIZE 36			
	2	9	TIE ROD SIZE 18			
1	1	8	STEM NUT			
2	2	7	BEARING ROD			
1	1	6	BEARING FLANGED			
2	2	5	BEARING WASHER			
1	1	4	PLATE GUIDE			
1	1	3	PLATE TOP			
1	1	2	HANDWHEEL MACH (10" DIA.)			
2	2	1	SCREW ST SDC 6-32X1/4 18-8			
QTY	DET.	DESCRIPTION				

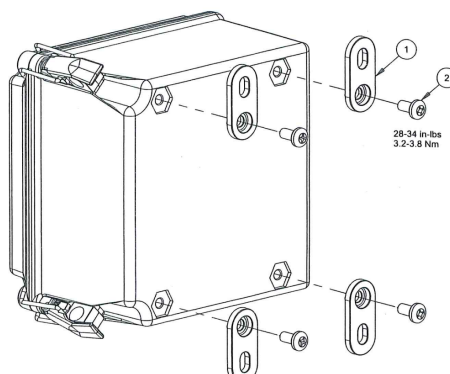

V. ELECTRICAL INSTALLATION



WARNING: REMOVE POWER FROM THE UNIT BEFORE INSTALLING, REMOVING, OR MAKING ADJUSTMENTS

GENERAL SAFETY

When using electrical equipment, you should always follow basic safety precautions, including the following:

- The installation and wiring of this product must comply with all national, federal, state, municipal, and local codes that apply.
- Properly ground the enclosure to an adequate earth ground.
- Do not modify any factory wiring. Connections should only be made to the terminals described in this section.
- All connections to the unit must use conductors with an insulation rating of 300V minimum, rated for 105C, a minimum flammability rating of VW-1, and be of appropriate gauge for the voltage and current required (see specifications).
- Do not allow moisture to enter the electronics enclosure. Conduit should slope downward from the unit housing. Install drip loops and seal conduit with silicone rubber product.



DISCONNECT REQUIREMENTS FOR PERMANENTLY INSTALLED EQUIPMENT

A dedicated disconnecting device (circuit breaker) must be provided for the proper installation of the unit. If independent circuits are used for power input and main relay outputs, individual disconnects are required.

Disconnects must meet the following requirements:

- Located in close proximity to the device
- Easily accessible to the operator
- Appropriately marked as the disconnect for the device and associated circuit
- Sized appropriately to the requirements of the protected circuit (See specifications)

PROTECTIVE EARTH GROUND

To eliminate shock hazards in the unlikely event of an internal insulation breakdown, the unit is provided with a “protective earth” () lead which must be connected to earth ground. In addition, the input power ground lead must be connected to the “protective earth” () terminal provided. Wire sizes must be selected such that it can safely carry the sum total of all circuits’ maximum amperage.

INSTALLATION

The ForceMeter is usually mounted horizontally but it can be mounted in any position provided that proper meter zeroing is performed before the operation of the meter. Care must be taken to keep the electrical connections clean and moisture free. It is advisable to inform the manufacturer of the chosen mounting position when ordering for proper compensation of sensor’s offset due to the gravity. Protect all connections with a silicone

moisture proof compound.

The target is a disc that has been accurately sized to produce the correct force for the chosen flow rate. The ForceMeter is shipped with the target retracted within the lower housing assembly to protect the target during installation. ForceMeters are shipped with a RTD temperature sensor mounted very close to the target sensing section for temperature compensation. Both the RTD and the sensing element are in a small, sealed metallic tube adjacent to the target. Avoid rough handling of the sensing tube and its target.

ELECTRICAL - 2 WIRE

Integral Transmitter - 2 Wire

For meters with integral transmitter mounting, remove the rear enclosure cover to access the 4-20 mA loop connections. Connect the positive wire of the power source to the terminal block pin marked (+) and the negative (return) wire of the DC source to the terminal block pin marked (-). See Figure 8. Integral 2 Wire Transmitter Wiring.

Figure 8. Integral Transmitter Wiring - 2 Wire

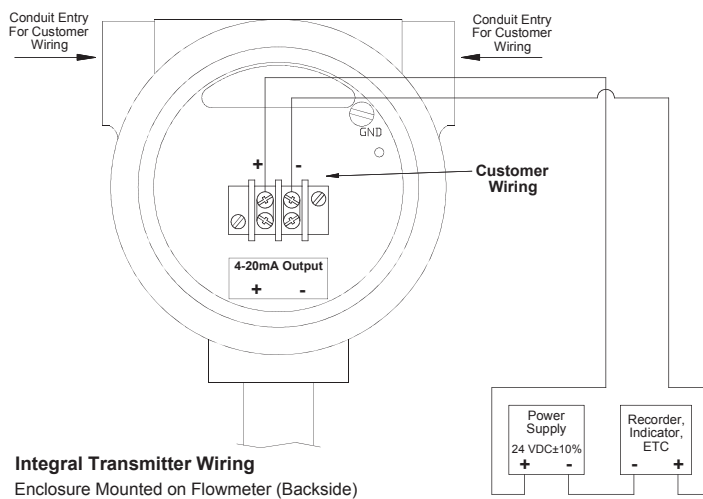

Analog instruments used to monitor the 4-20 mA loop (Figure 8. Integral Transmitter Wiring) may have an internal sense resistor or require a sense resistor be placed in the loop and the instrument is then connected across it. Since the ForceMeter operates from a DC supply of 24 VDC \pm 10% VDC volts, the total loop resistance allowed (sum value of all sense resistors) is limited.

Use the following formula to calculate the minimum power supply voltage required for the given total loop resistance. Make sure that the applied loop voltage range is within the recommended 24 VDC \pm 10% VDC:

- The Minimum Power Supply Voltage = $12 + (0.020 \times R_s)$, where R_s is the total loop resistance.

Example: Assuming the internal sense resistor of the analog instrument is 500 Ohms, then minimum power supply voltage for proper operation of the transmitter is: Minimum Power Supply Voltage = $12 + (0.020 \times 500) = 22$ VDC.

HART Communication - 2 Wire

The ForceMeter can be accessed using a variety of HART compliant devices. See Figure 10. HART Wiring. HART Protocols are available; please see ForceMeter HART Protocol Guide.

The received value for the HART current sense resistor is 500 ohms as shown in Figure 10.

To determine the minimum supply voltage, refer to the Minimum Power Supply equation. Remember that the value of the HART current sense resistor must be included in the total loop resistance.

Figure 10. HART Wiring Integral Transmitter - 2 Wire

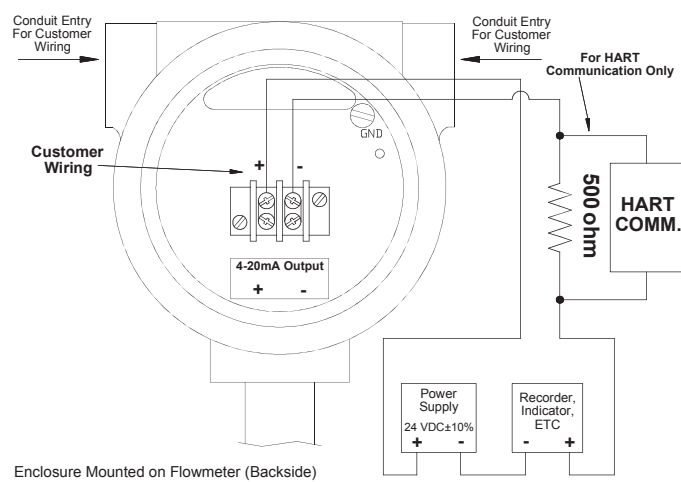
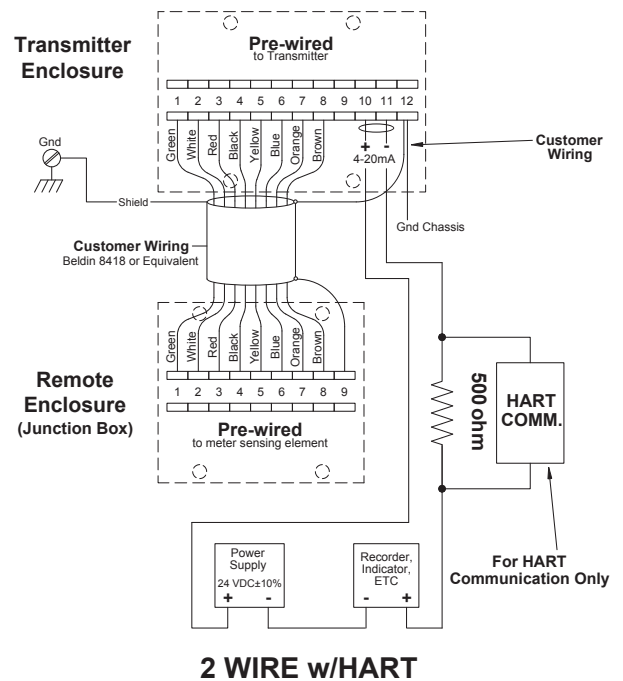

Figure 11. HART Wiring Remote Transmitter - 2 Wire



ELECTRICAL - 3 WIRE

Integral Transmitter - 3 Wire

Remove the back cover to access the power connection terminal block. This terminal block has 3 positions marked +24 VDC, GND, 4-20 mA. Connect the DC power source of 24VDC \pm 10% to the +24 VDC and GND (the unit is reverse polarity protected). To monitor the 4-20 mA output, connect the positive input of a measuring device to 4-20 mA and its negative input to GND. The 4-20 mA output can operate properly with a series resistor of up to 500 ohms in value.

Figure 12. Integral Transmitter Wiring - 3 Wire

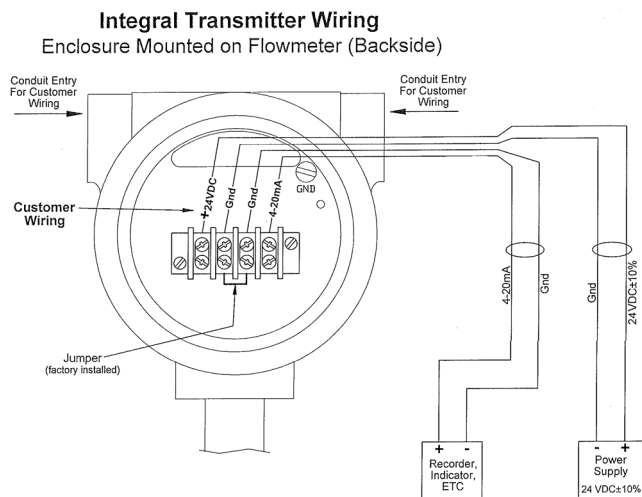

Remote Transmitter - 3 Wire

For remote mounted transmitters, remove the covers on the meter enclosure and transmitter enclosure to access the terminal strips. Use eight conductor cables (Beldin 8418 or equivalent) to connect the meter terminals to the transmitter terminals. The 4-20 mA loop connections are accessible in the transmitter enclosure.

Figure 13. Remote Transmitter Wiring - 3 Wire

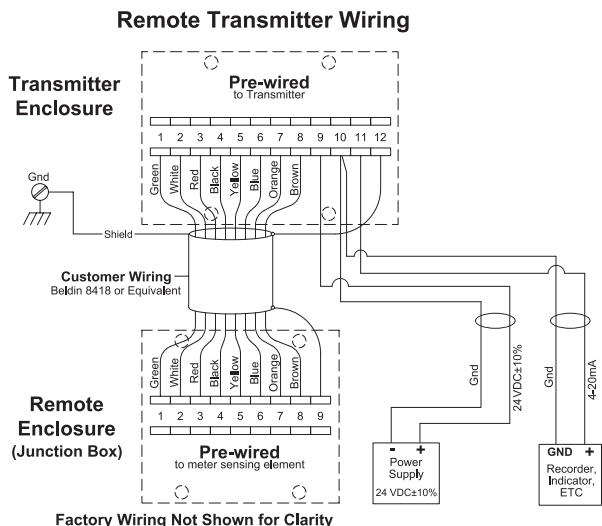

HART Communication - 3 Wire

The ForceMeter can be accessed using a variety of HART compliant devices. See Figure 10. HART Wiring. HART Protocols are available; please see ForceMeter HART Protocol Guide.

The received value for the HART current sense resistor is 500 ohms as shown in Figure 10.

To determine the minimum supply voltage, refer to the Minimum Power Supply equation. Remember that the value of the HART current sense resistor must be included in the total loop resistance.

Figure 14. HART Wiring Integral Transmitter - 3 Wire

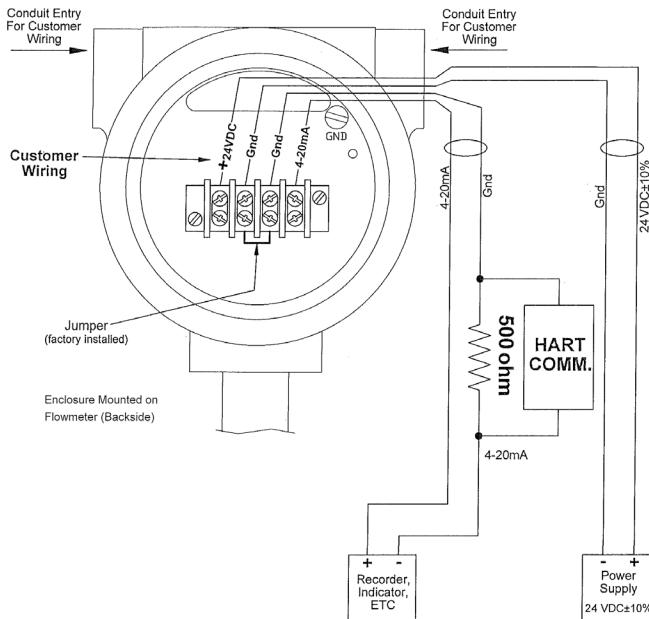
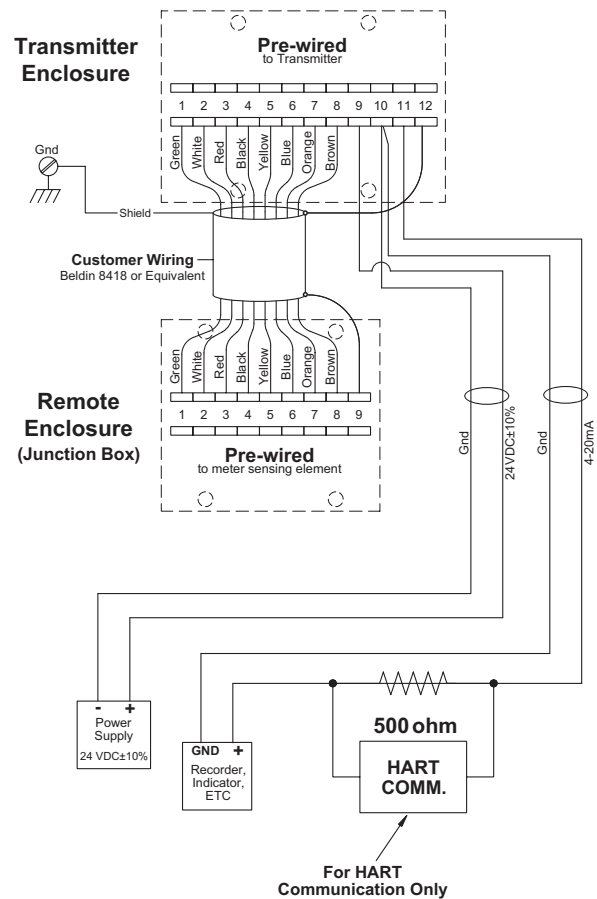

Figure 15. HART Wiring Remote Transmitter - 3 Wire



VI. SET-UP

TRANSMITTER OPTIONS

DISPLAY DESCRIPTION

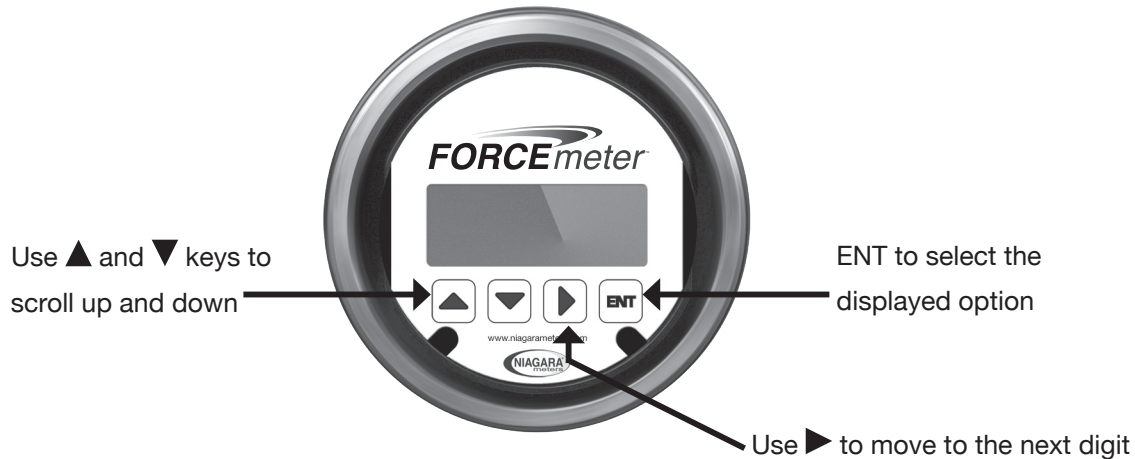

ACCESSING THE MENU

1. Press ENT and ▲ simultaneously
2. Enter password. Please Note: Default password is 8960
3. Use the ▲ and ▼ keys to increment or decrement the selected digit
4. Use the ► key to select the next digit
5. Press ENT to accept the password

ZEROING MODE

1. Press ENT and ▲
2. Enter password and press ENT
3. Menu will display:

<p>MAIN MENU EXIT</p>

4. Use the ▲ and ▼ keys until **ZERO METER** is displayed then press ENT
5. Menu will display:

<p>FLOW = ZERO? NO</p>
--

6. Use ▲ to select **YES**
7. Press ENT

<p>NOTE: Display can be configured to display Rate and Total, Rate only, and Total only. What your display shows in operation mode depends on how your display is configured.</p>
--

8. Menu will display:

**SET ZERO?
NO**

9. Use ▲ to select YES

10. Press ENT

11. Once the meter is zeroed the menu will display:

**SET ZERO
COMPLETE**

12. Menu will return to display:

**MAIN MENU
ZERO METER**

13. Use the ▲ to scroll up for EXIT, then press ENT

14. Display will return to operation mode

RESETTING TOTAL MODE

In order to reset the total for the flow meter, access the Main Menu by entering the password information.

See ACCESSING THE MENU section in this manual.

**MAIN MENU
RST TOTAL**

Once the RST TOTAL option is selected by pressing ENT the meter will ask you to verify by selecting YES or NO.

Use the scroll arrows to select YES or NO and then press ENT to accept the selection.

If NO is selected the meter will return to the main menu where another selection can be made.

If YES is selected the meter will perform the reset and display RST TOTAL COMPLETED on the display before returning to the main menu.

ACCESSING SIMULATE MODE

In order to enter simulation mode for the flow meter, begin by accessing the Main Menu by entering the password information.

See ACCESSING THE MENU section in this manual.

**MAIN MENU
SIMULATE**

Press ENT to select simulate mode. The SIMULATE menu options are:

- 4 mA to force 4 mA output
- 8 mA to force 8 mA output
- 12 mA to force 12 mA output
- 16 mA to force 16 mA output
- 20 mA to force 20 mA output

Once the output is selected press ENT.

An asterisk (*) will be placed by that output signal indicating this is the chosen signal.

To end simulation, press the arrow keys until BACK is available and press ENT.

ACCESSING PROGRAM MODE

Please consult manufacturer before changing program settings.

In order to enter program mode for the flow meter, begin by accessing Main Menu by entering the password information. See ACCESSING THE MENU section in this manual.

In Program Mode change Flow Type, Units, Range settings, Calibration, Display options, etc.

**MAIN MENU
PROGRAM**

MAIN MENU			
PROGRAM	BI-DIRECT	FACTORY SET	
	SPECIAL	FAILSAFE	
		DISPLAY	
		DAMPING	
		TRIM	
		CLR FAULT	
		FAULT HIST	
		DEFAULT	
		CHANGE PW	
		METER INFO	
		BACK	
	DECIMAL	RATE DECIMAL PLACE SELECTION	
	SET CAL	FACTORY SET	
	CUST SCALE		
	RANGE SET		
	TOTAL UNIT		
RATE UNIT			
FLOW TYPE	FACTORY SET		
BACK	BACK ONE LEVEL		

Please consult factory before attempting changing the Calibration values, Flow direction or Flow type.

PROGRAM MODE INFORMATION

FLOW TYPE

To change Flow Type from volumetric or mass flow, scroll to MASS or VOLUME and press ENT. Once a selection is made an asterisk (*) will appear next to that selection made indicating which flow type has been selected. Once a selection has been made, scroll to the BACK option and press ENT to go back to the Main Menu.

RATE UNIT

The Rate Unit is the engineering units to be displayed for flow rate on the meter. Selection choices for rate unit vary based on flow type. Scroll to the desired units and press ENT. The meter will place an asterisk (*) next to the selected option. Scroll to BACK option once a selection has been made to return to the main menu.

Rate Options For Volumetric Flow

UNIT	DESCRIPTION	UNIT	DESCRIPTION
GPS	gallons/second	CFH	cubic feet/hour
GPM	gallons/minute	CFD	cubic feet/day
GPH	gallons/hour	BPS	barrels/second
GPD	gallons/day	BPM	barrels/minute
MGD	mega gallons/day	BPH	barrels/hour
LPS	liters/second	BPD	barrels/day
LPM	liters/minute	IGS	imperial gallons/second
LPH	liters/hour	IGM	imperial gallons/minute
MLD	mega liters/day	IGH	imperial gallons/hour
CMS	cubic meters/second	IGD	imperial gallons/day
CMM	cubic meters/minute	NCH	normal cubic meter/hour
CMH	cubic meters/hour	NLH	normal liter/hour
CMD	cubic meters/day	%	percentage
CFS	cubic feet/second	SCM	standard cubic feet/minute
CFM	cubic feet/minute		

Rate Options for Mass Flow

UNIT	DESCRIPTION	UNIT	DESCRIPTION
GPS	grams/second	PPS	pounds/second
GPM	grams/minute	PPM	pounds/minute
GPH	grams/hour	PPH	pounds/hour
KPS	kilograms/second	PPD	pounds/day
KPM	kilograms/minute	STM	short tons/minute
KPH	kilograms/hour	STH	short tons/hour
KPD	kilograms/day	STD	short tons/day
MTM	metric tons/minute	LTH	long tons/hour
MTH	metric tons/hour	LTD	long tons/day
MTD	metric tons/day	%	percentage

TOTAL UNIT

The Total Unit is the engineering units to be displayed for the Totalizer on the meter. Selection choices for the Total Unit vary based on Flow Type. Scroll to the desired units and press ENT. The meter will place an asterisk (*) next to the selected option. Scroll to BACK option once a selection has been made to return to the PROGRAM menu.

Total Options for Volumetric Flow

UNIT	DESCRIPTION	UNIT	DESCRIPTION
GAL	gallon	CF	cubic feet
LIT	liter	CL	cubic liter
IGL	imperial gallon	BBL	bbl liquid
CM	cubic meter	NCM	normal cubic meter
BL	barrel	NL	normal liter
BSL	bushel	SCF	standard cubic feet
CY	cubic yard	HL	hectoliters

Total Options for Mass Flow

UNIT	DESCRIPTION	UNIT	DESCRIPTION
G	grams	ST	short tons
KG	kilograms	LT	long tons
MT	metric tons	OZ	ounces
LB	pounds		

RANGE SET

The Range Set option scales the 4-20 mA output to the process variable. In order to set the Range Set scroll to the Range Set option on the Program Menu and press ENT. Use the arrow keys to display the options. Selection choices for Range Set vary based on the direction of the meter.

Unidirectional Meter Options:

- 4 mA
- 20 mA
- CUT OFF

Initial range values are 4 mA = 0 flow and 20 mA = Full Scale flow designated by the invoice and application process. For a Unidirectional Meter the Cut Off will be the minimum flow that can be reported by the meter.

Bidirectional Meter Options:

- MaxRange
- CUT OFF

The 4 mA option will be the output when flow reaches this value in reverse direction. The Max Range option is the output when flow reaches this value in the positive direction. CUT OFF which is a process variable that allows the meter to report zero flow in both forward and reverse flow.

CUSTOM SCALE

The Custom Scale option is a percentage between 90 and 110, which can be selected to change the output factor to be displayed and transmitted. Select the desired option and press ENT to return to the PROGRAM menu.

SET CAL

The Set Cal option is set at the factory to match the transmitter to the target meter. This must not be changed without first consulting the factory.

DECIMAL

This option allows the decimal location that is displayed to be selected. The options are:

- 000000
- 0000.0
- 000.00

NOTE: The number of decimal digits will be limited by the full-scale value.

Scroll to the desired display option and press ENT. The meter will place an asterisk (*) next to the selected option. Scroll to BACK option once a selection has been made to return to the PROGRAM menu.

SPECIAL

- METER INFO will sequence through the serial number, firmware version, and model numbers, etc. that are assigned to the meter.
- CHANGE PW is the option to change the password for the meter
- DEFAULT resets the meter back to the original factory defaults set when the meter was shipped.
- FAULT HIST shows all the faults and warnings history that had occurred in meter during operation.
- CLR FAULT clears all active faults stored in the meter.
- TRIM provides an option to trim 4 mA and 20 mA output independent of flow.
- DAMPING provides an option to manage the displayed flow rate and mA output caused by severe turbulence or other conditions. Possible settings are 0 - 99 where 1 = 0.333 seconds, 2 = 0.666 seconds, 3 = 0.999 seconds, 90 = 29.97 seconds. The default setting is 3.
- DISPLAY provides the option to select the parameters to display on the meter. Standard is Flow Rate and Total. Options include Rate Only and Total Only.
- FAILSAFE provides the option to select the value the 4-20 mA is to transmit in the case there is a failure. Starting value is always ON LOW. Possible values are ON LOW, ON HIGH, and ON OTHER. Where ON LOW is 3.5 mA, ON HIGH is 22.5 mA, and ON OTHER is between 4 mA and 20 mA.

BIDIRECT

The Bidirect mode allows the meter to be set in unidirectional or bidirectional flow. Scroll to NO for unidirectional and YES for bidirectional flow. Scroll to the desired display option and press ENT. The meter will place an asterisk (*) next to the selected option. Scroll to BACK option once a selection has been made to return to the PROGRAM menu. This option is only available with a bidirectional meter. Please consult order information.

CALIBRATION

Except for extreme conditions, no calibration is required.

Due to fast response of the ForceMeter, flow fluctuations and transients may be seen which cannot be detected by other systems of flow measurement. What may appear to be instability in the ForceMeter may actually be instability in the fluid system. The flow range of any instrument may be altered, within certain limits, by the installation of a new target. Do not disassemble the sealed sensing element, as any unauthorized repairs will void the manufacturer's warranty.

FIELD CALIBRATION

NOTE: This is for unidirectional meters; for bidirectional, consult factory.

An important feature of the ForceMeter is the ease with which the retention of calibration accuracy can be verified in the field. By removing the ForceMeter from the line and making two simple checks, it can readily be determined whether the calibration is unchanged. In addition to the normal components of the flow system, the following is required: (a) a digital multimeter capable of reading milliamps, (b) a precision vernier caliper or micrometer and (c) a weight of known mass.

At the time the ForceMeter is calibrated by the manufacturer, the calibration parameters (including the target diameter and the full scale force) are recorded on the data sheet and supplied with the ForceMeter. These are also stored in the transmitter (Special Menu/Meter Info). If these measurements are unchanged, the calibration is unchanged. The sensor body (disc-shaped target) is sized and the edge contoured to obtain a desired drag in the moving stream of fluid. Comparison of the diameter of the disc at its edge with the diameter as measured when calibrated will show whether the drag is unchanged. The effect of the drag is to produce a force on the target support rod, resulting in an electrical output signal from the strain gage transducer in the ForceMeter. The relationship of the force on the rod to the signal is called the force factor and is a measure of the system sensitivity. A comparison of the force factor to that recorded when calibrated will show whether the sensitivity is unchanged.

To make the field checks, the ForceMeter should be removed from the line and the target removed from the support rod that is the upstream face of the target. At this time, the diameter can be measured using a vernier caliper or micrometer. Note: On bi-directional targets, both the upstream and downstream edges should be measured if the Target Type is SPIR . The target size listed on the data sheet includes a number which is the diameter of the target in thousandths of an inch. For example ACR-405 is a target with a diameter of 0.405”.

Note: On inline units it is advisable to carefully replace the o-ring when reassembling the meter into its housing.

With the target still removed, fasten a thin wire to the rod at the point where the center of the target would be. Then clamp the ForceMeter so that the forward flow direction is truly vertical and acting downward. Connect the ForceMeter per the wiring instructions in section ELECTRICAL. Connect the digital multimeter and apply power.

Before hanging a weight, record the programmed settings for Custom Scale and Cal 1 through Cal 8. These will need to be returned to their initial values after performing the field calibration test.

Refer to Accessing the Menu programming section CUSTOM SCALE and SET CAL. Custom Scale = _____

CHANGE CUSTOM SCALE TO 100

Do not change Cal 1, Cal 2, Cal 6, Cal 7 or Cal 8

After recording Custom Scale Cal 3, Cal 4 and Cal 6 change to 500

Cal 1 = _____

Cal 2 = _____

Cal 3 = _____

Cal 4 = _____

Cal 5 = _____

Cal 6 = _____

Cal 7 = _____

Cal 8 = _____

Zero the meter using the procedure in the section ZEROING THE METER. Using the digital multimeter, 4 mA should be displayed. This output signal is the zero load output. Hang a known weight, the full-scale weight, from the thin wire. Record the resulting test load output signal as indicated on the digital multimeter.

- If equal to the full-scale weight the milliamp output should read 20 mA DC.
- If less than the full-scale weight calculate the theoretical mA DC output:

$$\left(\sqrt{\frac{\text{Weight Used}}{\text{Full-Scale Weight}} \times 16} \right) + 4$$

If this reading is within 2-3% of that given, then the ForceMeter is operating with its original calibration. Small variances in calibration can be due to differences in measuring equipment, positioning compared to factory, etc. If readings are greater than 3%, or if you prefer specific settings, please refer to Apendix 5.

Return Custom Scale and Cals 1- 8 to the recorded numbers.

VII. MAINTENANCE AND REPAIR

The ForceMeter is not designed to be serviced by customers. Please consult the manufacturer.

VIII. TROUBLESHOOTING

2 WIRE FAULT CODES

FAULT CODES	DESCRIPTION	ACTION TO TAKE
1	Internal 2.5 V reference voltage	Check whether stable DC power is connected to transmitter. Clear fault from Failsafe to RUN mode. If fault appears again after clearing then contact manufacturer.
2	Internal 1.25 V reference voltage	See Action for Fault Code 1.
3	Bridge excitation voltage	See Action for Fault Code 1.
4	Not Used	-
5	Bridge connector not plugged in	Connect Bridge to Transmitter. Please clear fault to switch from Failsafe to RUN mode.
6	Bridge element fault (open/short)	See Action for Fault Code 1.
7	Not Used	-
8	AD12 communication	See Action for Fault Code 1.
9	DPOT communication	See Action for Fault Code 1.
10	Not Used	-
11	AD24 communication	See Action for Fault Code 1.
12	Not Used	-
13	Not Used	-
14	Flash read error	See Action for Fault Code 1.
15	Flash write error	See Action for Fault Code 1.
16	Not Used	-
17	Processor main clock failure	See Action for Fault Code 1.
18	Processor auxillary clock failure	See Action for Fault Code 1.
19	Not Used	-
20	Internal 2.5 V reference voltage warning	Please check whether stable DC power is connected to Transmitter.
21	Internal 1.25 V reference voltage warning	Please check whether stable DC power is connected to Transmitter.
22	Bridge operating temperature over/under range	Device detected fluid temperature more than it can handle. Please refer specification of device.
23	Process variable over/under flow	Device detected flow range more/below than Transmitter can handle. Please refer specification of device. Please clear fault to switch from Failsafe to RUN mode.
24	Bridge RTD failure	See Action for Fault Code 1.

3 WIRE FAULT CODES

FAULT CODES	DESCRIPTION	ACTION TO TAKE
1	Timer A error	Check whether stable DC power is connected to transmitter. Clear fault from Failsafe to RUN mode. If fault appears again after clearing then contact manufacturer.
2	Timer B error	See Action for Fault Code 1.
3	System Zero Scale error	See Action for Fault Code 1.
4	System Full Scale error	See Action for Fault Code 1.
5	Bridge connector not plugged in	Connect Bridge to Transmitter. Please clear fault to switch from Failsafe to RUN mode.
6	Bridge element fault (open/short)	See Action for Fault Code 1.
7	ADC7730 Continuous Conversion	See Action for Fault Code 1.
8	AD12 communication	See Action for Fault Code 1.
9	System is not calibrated	See Action for Fault Code 1.
10	Not Used	-
11	AD7730 stored parameter error	See Action for Fault Code 1.
12	Not Used	-
13	Not Used	-
14	Not Used	-
15	Not Used	-
16	Not Used	-
17	Processor main clock failure	See Action for Fault Code 1.
18	Processor aux. Clock failure	See Action for Fault Code 1.
19	Not Used	-
20	Not Used	-
21	Core Temp is over 150C	Electronic temperature is out of specification.
22	Bridge operating temperature over/under range	Device detected fluid temperature more than it can handle. Please refer specification of device.
23	Process variable over/under flow	Device detected flow range more/below than Transmitter can handle. Please refer specification of device. Please clear fault to switch from Failsafe to RUN mode.
24	Bridge RTD failure	See Action for Fault Code 1.
25	Active Slew mode error	See Action for Fault Code 1.
26	Error on Iout pin is detected	See Action for Fault Code 1.

IX. DIMENSIONAL DRAWINGS

Figure 16. Retractable Insertion

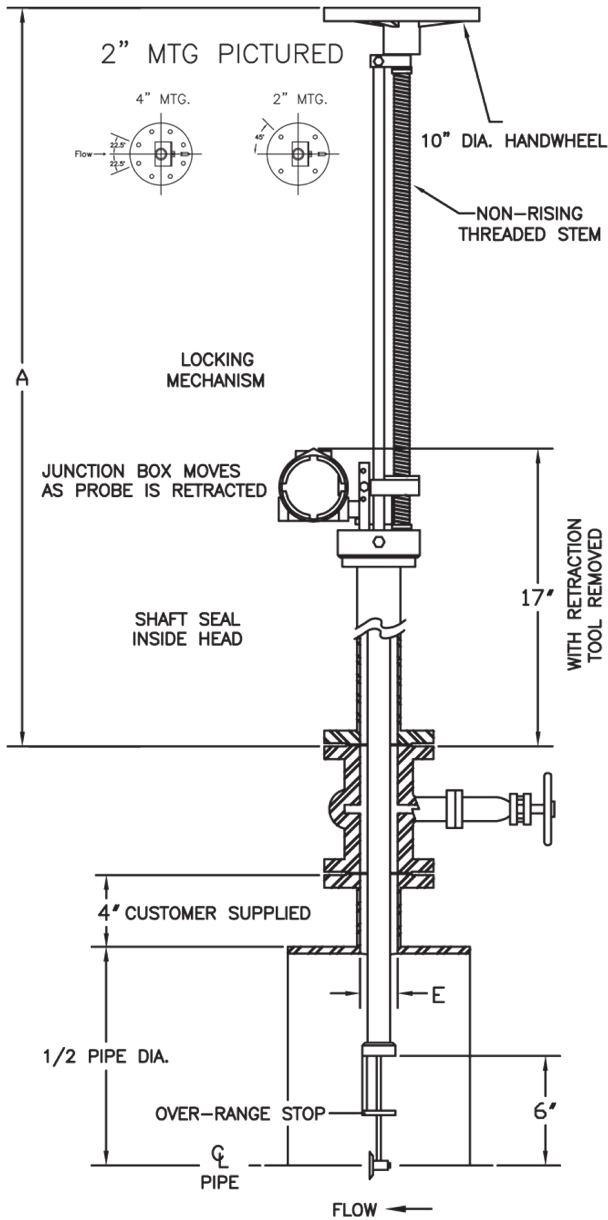
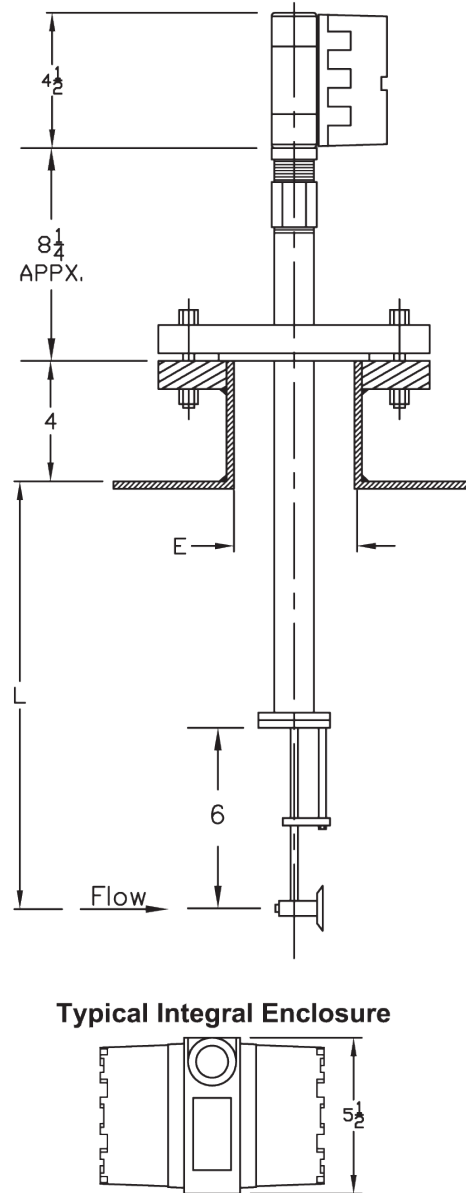

Figure 17. Fixed Insertion



Dimensions A (Retractable)

LINE SIZE	RETRACTION TOOL	DIM. A
4", 5", 6"	RT4-18	46 7/16
8", 10", 12"	RT4-18	46 7/16
14", 16", 18"	RT4-18	46 7/16
20", 22", 24"	RT20-36	55 7/16
26", 28", 30"	RT20-36	55 7/16
32", 34", 36"	RT20-36	55 7/16

Figure 18. Standard Mounting Options

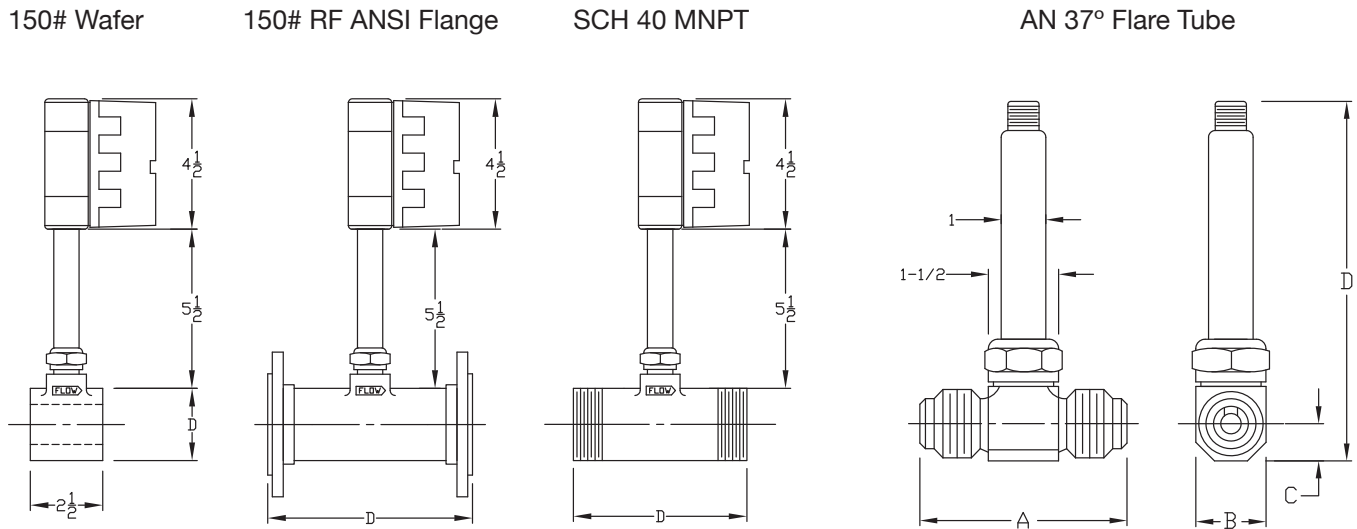

SIZE	D DIMENSION				
	Wafer	150# RF		MNPT	
		Dim.	Product Wt. (lbs.)	Dim.	Product Wt. (lbs.)
1/2"	1-3/4"	5"	8	4"	6
3/4"	2-1/8"	5"	9	4"	6
1"	2-1/2"	5"	9	5"	6
1-1/4"	2-7/8"	6"	11	6"	7
1-1/2"	3-1/4"	6"	12	6"	7
2"	4"	8"	18	8"	7
3"	5-1/4"	9"	28	9"	9
4"	6-3/4"	10-1/2"	40	-	-
6"	8-5/8"	12-1/2"	60	-	-

SIZE	DIMENSIONS				
	A	B	C	D	Product Wt. (lbs.)
1/2"	3.600"	1-3/8"	11/16"	7-5/8"	2.250
3/4"	3.600"	1-3/8"	11/16"	7-5/8"	2.250
1"	3.666"	1-3/8"	11/16"	7-5/8"	2.250
1-1/4"	3.666"	1-11/16"	7/8"	7-5/8"	2.500
1-1/2"	3.760"	1-15/16"	1"	8-1/8"	3.000
2"	4.260"	2-9/16"	1-5/16"	8-5/8"	4.500

Figure 19. Remote Enclosure

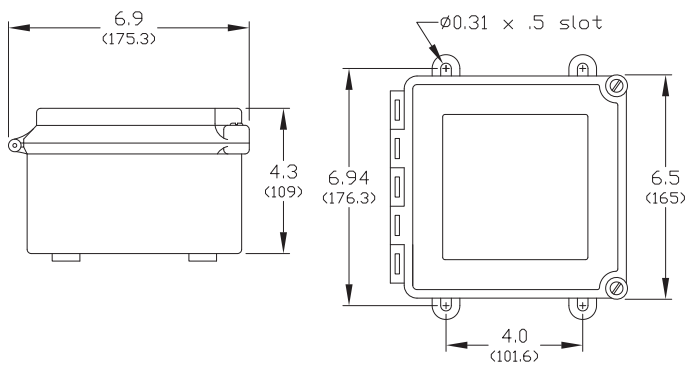
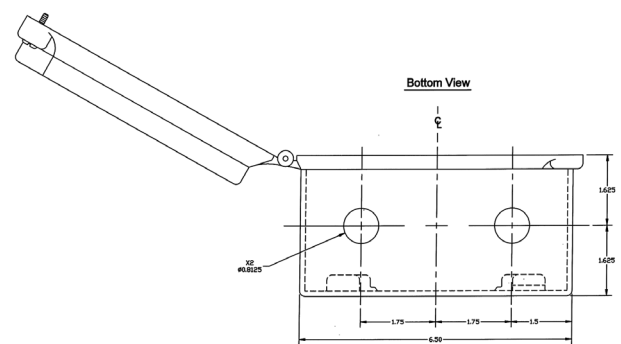

Figure 20. Remote Enclosure Conduit Locations



X. WARRANTY

A manufacturer's limited equipment warranty applies. Please consult the terms and conditions provided at the point of sale for a full description of the manufacturer's warranty. For a generic version of the warranty please consult the manufacturer.

XI. APPENDIX

1. THEORY

The instantaneous output of the strain gage bridge, E_{rl} , is directly and linearly proportional to the force, F , exerted on the target by the fluid flow. (Units defined at end of this section.)

$$E_{rl} = \frac{K}{2.2046} F$$

The total drag on any three dimensional body suspended in a fluid stream, gas or liquid, is the sum of the frictional drag and the pressure drag.

$$F_{total} = F_{frictional} + F_{pressure}$$

The frictional drag is equal to the integration of the shear stresses along the boundary of the body in the direction of the general motion of the fluid stream. The pressure drag is equal to the integration of the components in the direction of motion of all pressure forces acting on the bodies surface. Pressure drag is the dynamic component of the stagnation pressure acting on the projected area of the immersed body normal to flow.

When considering an equation to describe the response of the ForceMeter, only total drag is of interest and the equation becomes:

The total force due to turbulent fluid flow is proportional to the velocity head: $\frac{V^2}{2g}$

$$F_t = C_d A_p \frac{V^2}{2g}$$

This equation applies to fluid flows where turbulence exists over the complete flow range of interest. Turbulence will exist in the vicinity of the target when the pipe Reynolds Number (R_D , see equation below) is 2000 or greater and will predominate throughout the pipe cross-section when R_D is 2000 or greater. The value of R_D above which turbulence will exist is approximate, since turbulence is dependent on pipe roughness, entrance conditions and other factors. If, at the low end of the flow range R_D is 2000 or greater, the output is unaffected by variations in fluid viscosity and affected only by changes in fluid density (ρ). If at the low end of the flow range, R_D is between 1000 and 2000, the output for that part of the flow range may be affected by viscosity.

Laminar flow exists below $R_D = 400$ and a transition range exists between 400 and about 2000. The drag coefficient of the target (C_d) may vary in an unpredictable manner when R_D is in the transition or laminar regions. The low R_D can be brought about by low flow, high viscosity or both.

Although behavior in these regions may not always be predictable, it is repeatable if the flow conditions are held constant. An actual flow calibration by the manufacturer can be provided to cover conditions such as those described.

The ForceMeter conditions the signal from the strain gage bridge described above and yields a 4-20 mA DC output signal linear to flow. The bridge is excited using an AC excitation that minimizes thermocouple effects. On units with an integral RTD thermal stability is achieved compensating for temperature changes with the ForceMeter's electronics and additional firmware.

A ForceMeter can be calibrated with one fluid and then used with another fluid without loss of precision if the data are corrected for density change and the viscosities of both fluids are closely similar to keep R_D within the same range. With all other factors constant, electrical output will vary directly with fluid density.

Volumetric Units

$$Q_2 = Q_1 \frac{S_1}{S_2}$$

Gravimetric Units

$$W_2 = W_1 \frac{S_2}{S_1}$$

Pipe Reynolds Number is computed from any of the equalities below.

$$R_D = R_D = 50.6 \frac{Q_1 \rho}{d \mu} = 6.31 \frac{W}{d \mu} = 3160 \frac{Q_1}{dV}$$

F = Applied Force in pounds

F_t = Total Drag force

C_d = Drag coefficient

A = Area of target (sq. ft.)

ρ = Fluid density, pounds per cubic ft.

V = Velocity through meter bore (ft. per second)

E_1 = Voltage output at calibration

E_2 = Voltage output, corrected for operating conditions

S_1 = Specific gravity at calibration

S_2 = Specific gravity of operating fluid

R_D = Reynolds number, for unobstructed pipe

Q_1 = Rate of flow, gallons per minute

Q_2 = Corrected rate of flow, gallons per minute

W_1 = Rate of flow, pounds per hour

W_2 = Corrected rate of flow, pounds per hour

d = Internal diameter of meter bore (inches)

ν = Viscosity, centistokes

μ = Viscosity, centipoise

g = Gravitational constant = 32.2 feet/second/second

K = Force factor, millivolts per volt of excitation, per kilogram of force

E_{r1} = Instantaneous voltage ratio output in millivolts/volt of excitation

Z_1 = Super compressibility factor of original gas

Z_2 = Super compressibility factor of new gas

2. VISCOSITY

Two distinct types of flow in pipe are normally referred to – laminar and turbulent. Laminar flow is characterized by cylindrical layers of fluid which glide smoothly over each other. A dye injected in laminar flow would travel in straight lines. In turbulent flow the particles of fluid travel in a random motion. A dye injected in a turbulent situation would be dispersed throughout the pipe. The situation in which flow is in the process of change between laminar and turbulent or vice versa is referred to as, the transition zone.

In the target ForceMeter, the force exerted on the target by flow is given by the following:

$$F = C_d A \rho \frac{V^2}{2g}$$

This equation applies to flows where turbulence exists over the complete flow range. Should the flow fall into the transition or laminar regions, the force exerted is given by different formulas. Therefore, if the ForceMeter is calibrated for use in turbulent flow and subsequently used in laminar or transition flow, the output from the ForceMeter will no longer be a square function as given by the above formula. However, an actual flow calibration can be provided to cover these conditions. To know when this special calibration is required, there must be a means of determining when laminar or transition flow will exist. This can be determined by calculating the pipe Reynolds number.

Reynolds number is the dimensionless combination of the pipe diameter and density, viscosity and velocity of flow. Put another way, it is the ratio of the dynamic forces of flow to the shear forces due to viscosity:

$$R_D = \frac{DV\rho}{\mu}$$

A simplified form would be:

$$R_D = \frac{3160Q_1}{dv}$$

Where Q_1 = flow rate in gpm

d = internal pipe diameter in inches

Turbulence will exist in the vicinity of the target when the pipe Reynolds number is 2000 or greater. Laminar flow exists below $R_D = 400$ and a transition range exists between 400 and 2000. These numbers are approximate since pipe roughness, entrance conditions and other factors influence the condition of the flow.

If throughout the flow range the Reynolds number is greater than 2000, the ForceMeter output will be unaffected by variations in fluid viscosity. A water flow calibration will adequately describe the conditions of flow. For Reynolds numbers less than 2000 a special calibration is required which simulates the conditions of flow. In other words, viscosity has an unpredictable yet repeatable effect at Reynolds numbers less than 2000. The Reynolds number of the special calibration is made to match the customer's Reynolds number so that the unpredictable effects of viscosity are determined. It should be noted that the customer's viscosity must be maintained in order to maintain calibration accuracy. The change to a different viscosity requires a new calibration.

3. CORRECTION FACTORS FOR VOLUMETRIC GAS FLOW

RATE WHEN OPERATING CONDITIONS CHANGE

A flow meter calibrated for use with a specified gas at given conditions of temperature and pressure can often be used to measure the flow rate when the operating conditions are changed. A change to a different gas can often be accommodated too.

There are three limitations:

- Do not apply higher pressures and/or higher temperatures that are beyond the limits of the flow meter internal design or the rating of the end connections. Check the flow meter data sheet.
- When the operating gas pressures exceed 100 psig, the ideal gas laws do not apply and the equations below must be modified by a super-compressibility correction factor. Refer to standard handbooks covering gas flows, or consult the manufacturer.
- The new operating conditions must not cause the indicated flow rate to go beyond the original flow range. If it would, check with the manufacturer on having the flow meter re-ranged.

Gas flow rates can be expressed two ways: (1) in ACFM, the actual cubic feet per minute of gas flowing at the operating temperature and pressure, or (2) in SCFM, the "standard" cubic feet per minute flowing at the operating temperature and pressure. The SCFM is a standard reference and indicates the flow rate in cubic feet per minute if the same weight of gas had been flowing at the "standard" conditions: 14.7 psia and 60° F.

When the flow being measured uses a different gas or the operating conditions are changed, then the indicated flow rate must be multiplied by a correction factor to obtain the new flow rate. Choose the correction factor from the equations below depending on the units used in the original calibrations and the units desired for the new flow rate.

Original in SCFM – New in SCFM:

$$V_2 = V_1 \sqrt{\frac{G_1 P_2 T_1 Z_1}{G_2 P_1 T_2 Z_2}}$$

Original in ACFM – New in ACFM:

$$V_2 = V_1 \sqrt{\frac{G_1 P_1 T_2 Z_2}{G_2 P_2 T_1 Z_1}}$$

Original in SCFM – New in ACFM:

$$V_2 = V_1 \frac{14.696}{519.67} \sqrt{\frac{G_1 T_1 T_2 Z_1 Z_2}{G_2 P_1 P_2}}$$

Original in ACFM – New in SCFM:

$$V_2 = V_1 \frac{519.67}{14.696} \sqrt{\frac{G_1 P_1 P_2}{G_2 T_1 T_2 Z_1 Z_2}}$$

V_1 = indicated volumetric flow rate (equal to true flow rate at original calibration)

V_2 = volumetric flow rate at new conditions

G_1 = specific gravity of original gas

G_2 = specific gravity of new gas

P_1 = original pressure of gas at operating conditions, psi absolute

P_2 = new pressure of gas at operating conditions, psi absolute

T_1 = original temperature of gas at operating conditions, degrees Rankine

T_2 = new temperature of gas at operating conditions, degrees Rankine

Z_1 = super compressibility factor original calibration

Z_2 = super compressibility factor new conditions

Note: Below 150 psi Z can be ignored.

(Degrees Rankine = degrees F + 459.67)

Note: Standard conditions are considered to be 14.696 PSIA and 60°F (519.67° R).

Air = 0.0764 lbs/ft³

Water = 62.3714 lbs/ft³

Note: If any of the three parameters, specific gravity, pressure or temperature are unchanged eliminate that parameter from the equations.

4. CORRECTION FACTORS FOR STEAM FLOW RATE

A ForceMeter calibrated for use with steam at given conditions of temperature and pressure can often be used to measure the flow when the operating conditions change. There are two limitations:

- Do not apply higher pressures and/or temperatures that are beyond the limits of the ForceMeter internal design or the rating of the end connections. Check the flow meter data sheet.
- The new operating conditions must not cause the indicated flow rate to go beyond the original flow range. If it would, check with the manufacturer on having the ForceMeter re-ranged.

When the steam operating conditions change, then the indicated flow rate must be multiplied by a correction factor to obtain the new flow rate:

$$W_2 = W_1 \sqrt{\frac{Vg_1}{Vg_2}}$$

W_1 = indicated rate of flow, pounds per hour

W_2 = flow rate at new conditions, pounds per hour

Vg_1 = specific volume of steam at original conditions

Vg_2 = specific volume of steam at new conditions

5. CORRECTIONS FOR CHANGE IN FORCEMETER SENSITIVITY

At the time a ForceMeter is calibrated by the manufacturer, among the measurements made and recorded on the data sheet supplied with the ForceMeter is the force factor and full-scale weight. The force factor is a measure of the system sensitivity and arrived at by hanging a known weight, preferably 1 kilogram, from the lever arm of the ForceMeter element at the point where the target is attached and recording the corresponding output in mA DC. A change in the force factor of a calibrated ForceMeter, usually due to the replacement of the primary element, will affect the accuracy of the ForceMeter. However, a correction factor can be applied to the Custom Scale for a change in the system sensitivity thereby retaining the calibration accuracy.

Please refer to section FIELD CALIBRATION.

The force factor correction (K) is equal to the ratio of the forces:

$$K = \frac{F_1 - 4}{F_2 - 4}$$

$$\text{Where } F_1, \text{ Original mA DC} = \left(\sqrt{\frac{\text{Weight Used}}{\text{Full-Scale Weight}} \times 16} \right) + 4$$

Where F_2 is New Measured mA DC

If the reading with a known weight yields a milliamp reading greater than the calculated theoretical mA DC, the meter has become more sensitive. If the mA DC is less, it has become less sensitive. To make a correction multiply the Custom Scale by K.

Example for finding a Correction Factor:

The Full-scale Weight is 820 kg, the Weight Used is 700 kg, and the Custom Scale is 100.

$$\left(K = \frac{18.783 - 4}{19.960 - 4} \right) \times 100 = \text{Correction Factor of } 92.63\%$$

$$\text{Where } F_1, \text{ Calculated mA DC} = \left(\sqrt{\frac{700}{820} \times 16} \right) + 4 = 18.783 \text{ mA DC}$$

Where F_2 , New Measured mA DC = 19.960

NOTE: If Custom Scale is greater than 110 or less than 90, then STOP and consult factory.



150 Venture Boulevard
Spartanburg, SC 29306
Tel: (800) 778-9251
Tel: (864) 574-3327
Fax: (864) 574-8063
sales@niagarameters.com
www.niagarameters.com

venture
MEASUREMENT

2014 All rights reserved.
All data subject to change without notice.

FM20110700 Rev. H