

Features

- Compatible with all BC & FC Products
- Meets NEMA 4X/IP65 Specs.
- Quick-Release Latches
- Hinged Cover
- Light Weight



Application:

Ideal for use in most petrochemical plants, sewage plants, food processing areas, packing plants, electroplating plants, etc.

Material:

- Cover/Base - Ultraguard® Fiberglass reinforced polyester (Color RAL 7035)
- Fasteners - 304 series stainless steel
- Back panel inserts - Brass
- Gasket - Closed cell neoprene
- Mounting Feet - 304 series stainless steel

Test Spec:

Construction meets NEMA/EEMAC Type 1, 2, 3, 4, 4X, 12 & 13
 UL® 508 listed; Type 1, 2, 3, 3R, 4, 4X, 12, and 13
 CSA-C22 No. 14; Type 1, 2, 3, 3R, 4, 4X, 12, and 13
 IEC60529 Type IP66
 Compliant with RoHS (Restriction of Hazardous Substances)

Ordering Information

Model	Description
ENCC-W	BC & FC Wall Mount Enclosure

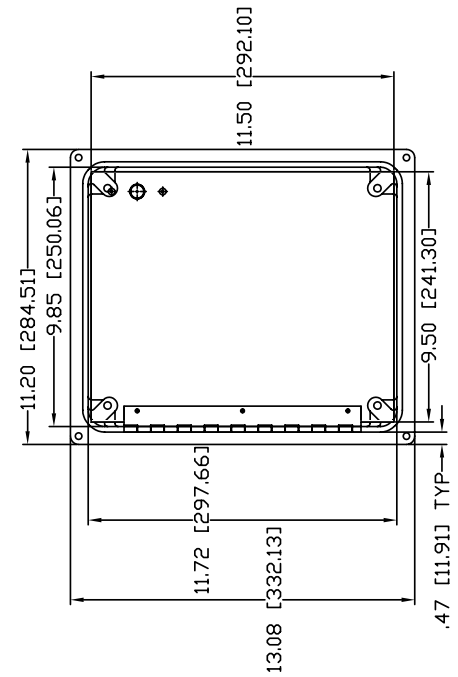
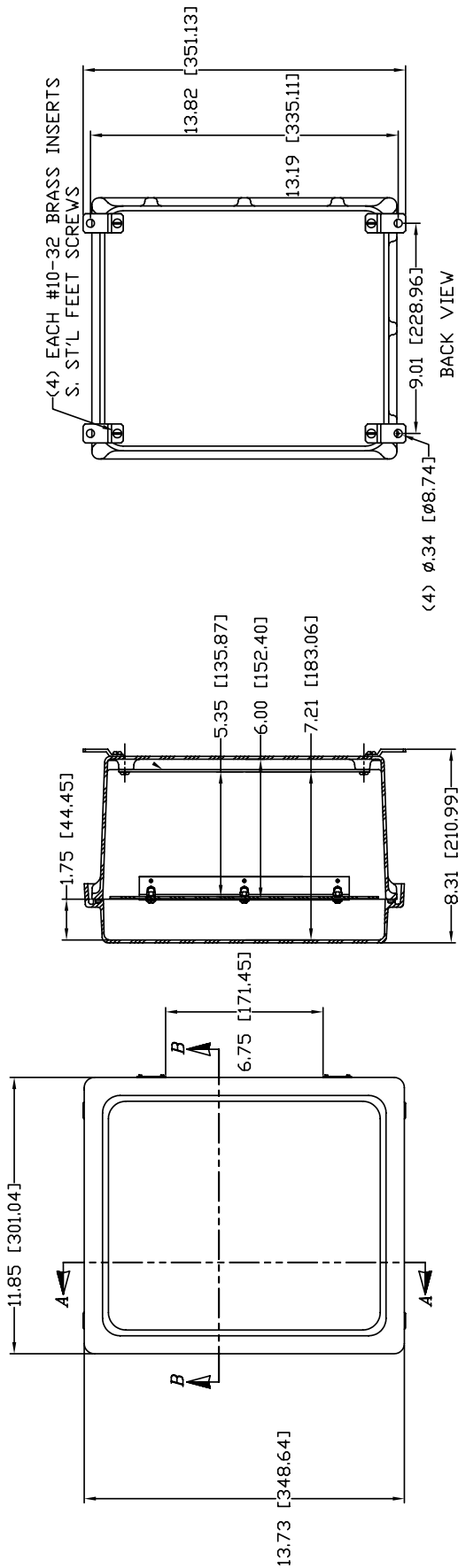

FRONT VIEW WITH LID REMOVED

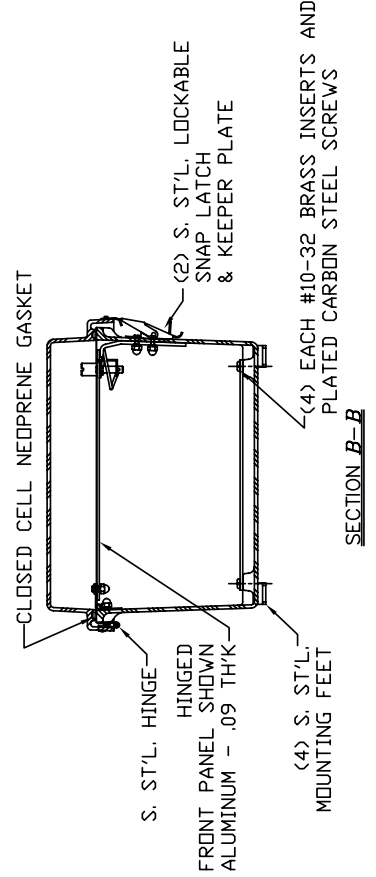

MATERIAL:
 BOX - COMPRESSION MOLDED FIBERGLASS REINFORCED POLYESTER
 COVER - COMPRESSION MOLDED FIBERGLASS REINFORCED POLYESTER
 WINDOWS - POLYCARBONATE