



Series WPX
Models 210 and 222

Installation, Operation
& Maintenance Manual



Model 210 – hot
Sizes 2”, 3”, 4”, 6”,
and 8”

Models 222-cold
Sizes 2”, 3”, 4”, 6”
and 8”



Table of Contents

Model 210 – Hot Water	
Installation & Operation	1
General	1
Installation	1
Operation	1
Options	1
Model 210 Maintenance	2
Register Removal	2
Removing Measuring Chamber	2
Installation of Measuring Chamber	2
Replacement Parts	3
Model 222 – Cold Water	
Installation & Operation	4
General	4
Installation	4
Operation	4
Options	4
Model 222 Maintenance	5
Register Removal	5
Removing Measuring Chamber	5
Installation of Measuring Chamber	5
Replacement Parts	6
Models 210 and 222 Specifications	6

Model 210 – Hot Water Installation & Operation

GENERAL

The red Niagara Series WPX turbine flowmeters are ideal for the measurement of water up to 250°F in commercial and industrial applications. These high performance meters are unsurpassed in the market place today.

INSTALLATION

The Niagara Series WPX turbine meter may be mounted in a horizontal or vertical pipe, but never with the register on the bottom.

In order to have accurate measurement, the meter must have 5 pipe diameters upstream and 3 pipe diameters downstream of straight uninterrupted pipe.

The WPX turbine must be placed in a pipeline free of scale, sediment, and debris. If there is excessive sediment in the pipeline, protect the meter by putting a strainer (20 mesh) upstream of the meter.

OPERATION

Air must be evacuated from the WPX turbine before operating. Slowly open valve to let water into the meter. Gradually increase the flow rate to drive out the air. If the meter is not filled slowly, the surge of water can damage the measuring elements.

OPTIONS

Model 860

- Provides a high frequency pulse output for interface with Venture Measurement instrumentation.
- Supply Voltage: 30 VDC max.
- Current Requirement: 15-20 mA.
- Output Signal: Non-symmetrical square pulse train (equal to supply voltage).
- Wiring: Pigtail, 36", 3-wire conductor.
- Max. Output Current: 20 mA.

Model 840

- Provides a calibrated contact closure.
- Contact Rating
Switching Voltage: 30 VDC max.
Current DC Resistive 0.2A max.
Wattage: 3 WDC max.
- Wiring: Pigtail, 36", 22 gauge

Model 210 Maintenance

REGISTER REMOVAL

Model 210

Totalizer with Reed Switch and Infrared Transmitter

1. Remove strain relief nut and draw out washer and binding nut.
2. Remove screws from register cover.
3. Remove register cover.
4. Slide reed switch or infrared transmitter out of the dovetail slot in the register.
5. Remove sealing wire out of sealing segment and working clamp ring.
6. Pull sealing segment out of ring.
7. Turn working clamp ring and register 90 degrees to the left or the right and lift off.
8. The register cannot be disassembled further. It is hermetically sealed and must be replaced as a unit if damaged.

Straight Totalizer

1. Remove the fillister head screws from the register cover and lift off cover.
2. Remove sealing wire.
3. Lift of sealing segment.
4. Turn clamp ring 90 degrees to the left or the right and lift it up with the counter.

REMOVING MEASURING CHAMBER

Model 210 – Sizes 2”, 3”, 4”, 6” & 8”

1. Loosen sealing wire.
2. Remove hex head screws.
3. Lift out measuring chamber housing.
4. If measuring unit is stuck, loosen it by prying on the cast recesses with a screw driver.
5. Check O-Ring for damage. Replace if necessary.

Model 210 – Size 10”

1. Loosen sealing wire.
2. Remove hex screws.
3. Grip measuring chamber housing by the two lifting eye bolts and lift out.
4. Check O-Ring for damage and wear. Replace if necessary.

INSTALLATION OF MEASURING CHAMBER

Model 210

Install the Model 210 by following the reverse order of the removal instructions. The following items should be checked:

- O-rings and lip washers should be checked for damages before installation.
- Slightly lubricate O-rings and regulator shaft.
- The slot of regulator drive has to be in line with the regulator vane in the starting position.

REPLACEMENT PARTS

- Measuring chamber complete
- Register assembly

Note: Part numbers are listed in the parts price book.

Model 210

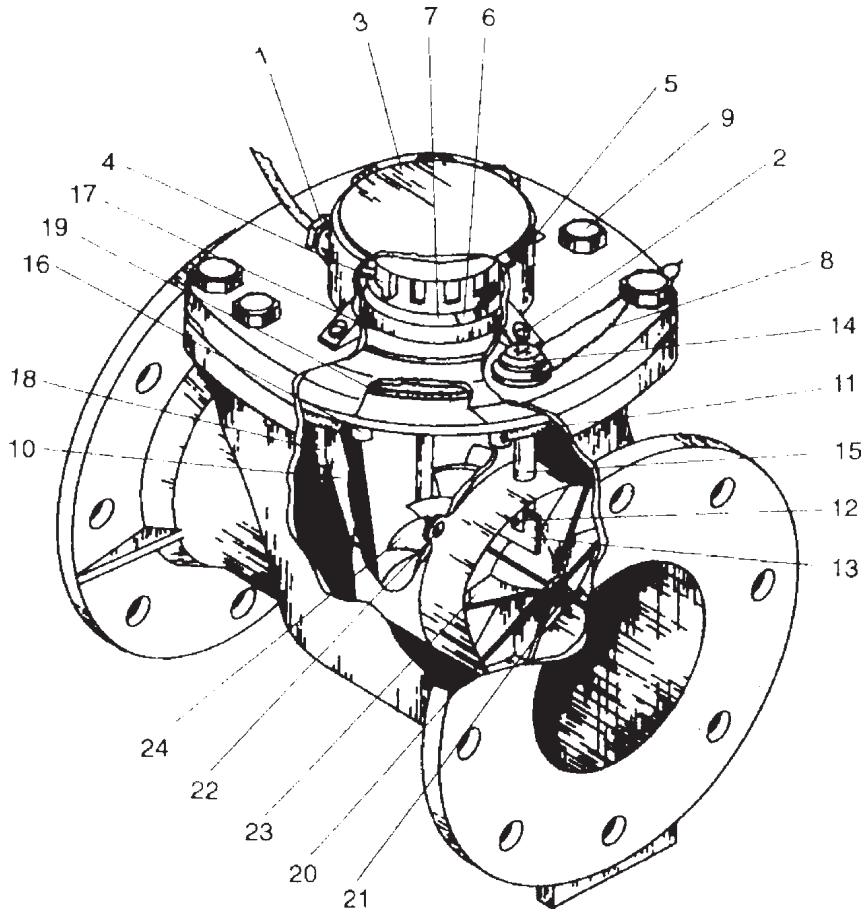

- 1 strain relief nut
- 2 register cover screws
- 3 register cover
- 4 reed switch or infrared transmitter
- 5 sealing wire
- 6 sealing segment
- 7 working clamp ring
- 8 sealing wire
- 9 hex head screws
- 10 measuring chamber housing
- 11 o-ring

Models 222 – Cold Water Installation & Operation

GENERAL

The blue Niagara Series WPX turbine flowmeters are ideal for the measurement of water up to 120°F in commercial and industrial applications. These high performance meters are unsurpassed in the market place today.

INSTALLATION

The Niagara Series WPX turbine meter may be mounted in a horizontal or vertical pipe, but never with the register on the bottom.

In order to have accurate measurement, the meter must have 5 pipe diameters upstream and 3 pipe diameters downstream of straight uninterrupted pipe.

The WPX turbine must be placed in a pipeline free of scale, sediment, and debris. If there is excessive sediment in the pipeline, protect the meter by putting a strainer (20 mesh) upstream of the meter.

OPERATION

Air must be evacuated from the WPX turbine before operating. Slowly open valve to let water into the meter. Gradually increase the flow rate to drive out the air. If the meter is not filled slowly, the surge of water can damage the measuring elements.

OPTIONS

Model 573

- Provides a high frequency pulse output for interface with Venture Measurement instrumentation.
- Supply Voltage: 24 VDC max.
- Current Requirement: 30 mA.
- Output Signal: Non-symmetrical square pulse train (equal to supply voltage).
- Wiring: Pigtail, 36", 2-wire conductor.
- Max. Output Current: 30 mA.

Model 840

- Provides a calibrated contact closure.
- Contact Rating
 - Switching Voltage: 30 VDC max.
 - Current DC Resistive 0.2A max.
 - Wattage: 3 WDC max.
- Wiring: Pigtail, 36", 22 gauge

Models 222 Maintenance

REGISTER REMOVAL

Model 222

1. Depress the tab in the register box below the hinge. Lift hinged side of register and rotate forward to remove it from the meter.
2. Remove the sealing tape from the locking segment and register retaining ring. Remove the locking segment from the retaining ring by prying straight up on the locking segment with a flat screwdriver.
3. Spread the retaining ring to remove it from the slot on the top case and remove it. Lift register off top case.
4. To re-assemble, reverse the order of the instructions above.

REMOVING MEASURING CHAMBER

Model 222 – Sizes 2”, 3”, 4”, 6”, 8”

1. Remove the sealing wire from the case bolts. Loosen the case bolts and remove them.
2. Lift top case and measuring chamber from the bottom casing.
3. Remove the rubber lip seal from the inlet side of the measuring chamber to expose the 3rd screw.
4. Remove the 3 screws securing the measuring chamber to the top case.
5. To replace the measuring chamber, reverse the order of instructions above.

Note: The lip seal and casing O ring should be inspected before re-assembly. Any worn or torn seals should be replaced.

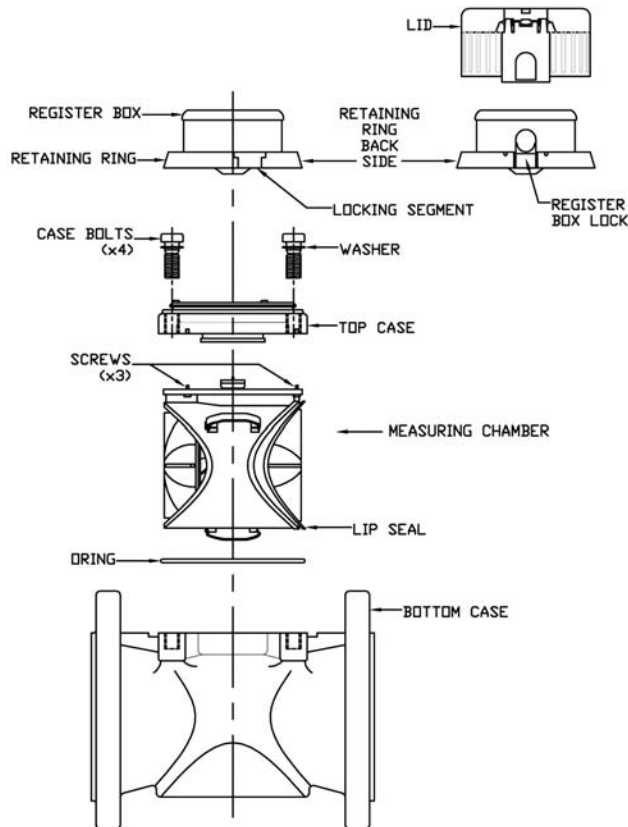

REPLACEMENT PARTS

- Measuring chamber complete
- Register assembly

Note: Part numbers are listed in the parts price book.

Models 210 (hot) Specifications

Size	2"	3"	4"	6"	8"
Flow Rate gpm	8-305	20-660	30-1100	45-1870	60-2860
Pressure psi	227	227	227	227	227
Temperature	250°F	250°F	250°F	250°F	250°F
Accuracy	± 1%	± 1%	± 1%	± 1%	± 1%
Registration*	USG	USG	USG	USG	USG
Gallons per contact with 840 Switch	10 or 100	100 or 1000	100 or 1000	100	100
Full Scale Freq. Hz with 860 Infra-Red Pulser	50.8	22	36.67	31.15	47.7
Pulses per Gallon*	10	2	2	1	1

Models 222 (cold) Specifications

Size	2"	3"	4"	6"	8"
Flow Rate gpm	4.4-396	3.5-880	7.9-1321	17.6-1541	26.4-2862
Pressure psi	227	227	227	227	227
Temperature	120°F	120°F	120°F	120°F	120°F
Accuracy	± 1%	± 1%	± 1%	± 1%	± 1%
Registration*	USG	USG	USG	USG	USG
Gallons per contact with 840 Switch	10 or 100	100 or 1000	100 or 1000	100 or 1000	100 or 1000
Full Scale Freq. Hz with 573 Infra-Red Pulser	66	14.7	22	26.7	47.7
Pulses per Gallon*	10	1	1	1	1

* Other units of registration available (consult factory). $\text{Hz} = \frac{\text{GPM} \times \text{PPG}}{60}$ $\text{PPG} = \frac{\text{Hz} \times 60}{\text{GPM}}$

Wetted Material of Construction

Body: Cast Iron
 Measuring Element: 120°F - Noryl
 250°F - Polyethersulfone
 Rotor: Polyamid
 O-Ring Seals: EPDM



150 Venture Boulevard
 Spartanburg, SC 29306

Phone: (800)778-9251, (864) 574-3327
 Fax: (864) 574-8063
 Internet: www.niagarameters.com
 E-Mail: sales@niagarameters.com